

# INSTALLATION OPERATION AND SERVICE MANUAL



## GAS FIRED COMMERCIAL COPPER TUBE BOILERS *BLUE-FLAME SERIES*



### FOR HYDRONIC HEATING

*Models; BFH 480, 660, 840, 1020, 1200, 1380, 1560, 1740,  
1950*



### HOT WATER SUPPLY

*Models; BFW 480, 660, 840, 1020, 1200, 1380, 1560, 1740,  
1950*



**WARNING:** If the information in these instructions is not followed exactly, a fire or explosion may result causing property damage, personal injury or death

- Do not store or use gasoline or other flammable vapours and liquids in the vicinity of this or any other appliance.
- **WHAT TO DO IF YOU SMELL GAS**
  - Do not try to light any appliance,
  - Do not touch any electrical switch; do not use any phone in your building,
  - Immediately call your gas supplier from a neighbour's phone. Follow the gas supplier's instruction,
  - If you cannot reach your gas supplier, call the fire department.
- Qualified installer, service agency or the gas supplier must perform installation and service.

To the installer: After installation, these instructions must be given to the end user or left on or near the heater.  
To the End User: This booklet contains important information about this heater. Retain for future reference.

## **CAMUS HYDRONICS LTD.**

6226 Netherhart Road, Mississauga, Ontario, L5T 1B7

99-0030  
Rev. 03.00

## Table of Contents

INTRODUCTION .....	1
1. GENERAL INSTRUCTIONS .....	1
2. BOILER LOCATION .....	2
3. PROVIDE AIR FOR COMBUSTION AND VENTILATION .....	2
4. ELECTRICAL WIRING .....	3
5. GAS SUPPLY AND PIPING .....	3
6. VENTING.....	4
7. SAFETY DEVICES .....	7
7.1 WATER FLOW SWITCH (shipped loose).....	7
7.2 LOW WATER CUTOFF (If Equipped) .....	7
7.3 RELIEF VALVE (shipped loose).....	7
8. FREEZE PROTECTION .....	7
9. WARNING REGARDING CHILLED WATER SYSTEMS .....	8
10. PIPING OF BOILER TO THE SYSTEM (FIG.3).....	8
11. PLACING BOILER IN OPERATION.....	10
12. CHECK OUT OF IGNITION SYSTEM SAFETY SHUT-OFF DEVICE.....	10
13. LOW WATER TEMPERATURE SYSTEMS.....	10
14. INSTANTANEOUS WATER HEATER.....	12
15. PILOT AND MAIN BURNER FLAMES.....	12
15.1. MAIN BURNER .....	12
15.2. PILOT BURNER.....	14
16. OPERATION AND SERVICE .....	15
17. LIGHTING INSTRUCTIONS .....	16
18. TROUBLE SHOOTING GUIDE .....	17
19. TYPICAL GAS TRAIN .....	18
20. ELECTRICAL DIAGRAMS.....	18
21. EXPLODED VIEW .....	21
22. BLUE FLAME REPLACEMENT PARTS LIST .....	22
WARRANTY .....	23

## **INTRODUCTION**

Camus Hydronics proudly introduces its Blue-Flame Series of Water Heaters / Hydronic Boilers. These machines are thoughtfully designed for easy operation and maintenance. We are confident that you will come to appreciate the benefits of our product.

### **1. GENERAL INSTRUCTIONS**

The installation of this heater must conform to the requirements of the authority having jurisdiction or, in the absence of such requirements, to the National Fuel Gas Code, ANSI Z223.1 or CAN/CGA B149 Installation Codes. All electrical wiring must be done in accordance with the requirements of the authority having jurisdiction or, in the absence of such requirements, with the National Electrical Code, ANSI/NFPA 70 or the Canadian Electrical Code Part I, CSA C22.1 Electrical Code.

Vent installations must be in accordance with Part 7, Venting of Equipment, of the National Fuel Gas Code, ANSI Z223.1, or Section 7, Venting Systems and Air Supply for Appliances, of the CAN/CGA B149.1, Installation Codes and applicable provisions of the local building codes.

When required by the authority having jurisdiction, the installation must conform to the Standard for Controls and Safety Devices for Automatically Fired Boilers, ANSI/ASME CSD-1.

The qualified installer shall instruct the end user in the safe and correct operation of this appliance and shall ensure that the heater is in safe working order prior to leaving the job site.

#### **WARRANTY:**

**Factory warranty shall apply only when the boiler is installed in accordance with:**

- **Local codes, standards, ordinances and regulations,**
- **The printed instructions provided with the boiler and;**
- **Good industry practices.**

**Excessive water hardness causing a lime build-up in the copper coils or tubes is not a fault of the boiler and is not covered by warranty. Consult the factory for recommendations for use in hard water areas.**

**Using or storing corrosive chemicals in the vicinity of this boiler can rapidly attack the copper tubes and coils and voids warranty.**

**This boiler is intended to operate under non-condensing conditions. Inlet temperatures must be maintained at 110°F or higher. Warranty is void if heater is allowed to operate in condensing mode.**

**Damage caused by freezing or dry firing voids warranty.**

**This boiler is not to be used for temporary heating of buildings under construction.**

## 2. BOILER LOCATION

Install this boiler in a clean, dry location with adequate air supply and close to a good vent connection.

Do not locate this boiler in an area where it will be subject to freezing.

The boiler must not be installed on carpeting and should be located close to a floor drain in an area where leakage from the boiler or connections will not result in damage to the adjacent area or to lower floors in the structure.

If necessary a suitable drain pan should be installed under the boiler.

If the boiler is installed above the level of the building's radiation system, a low water cutoff device must be installed in the boiler outlet at the time of installation. Some local codes require the installation of a low water cutoff on all systems.

Locate the boiler so as to provide adequate clearance for inspection and service all around the unit. It is recommended that 24" be provided for the top and sides and 48" for the front.

This boiler is suitable for alcove installation with minimum clearances to combustibles as follows:

TOP :	12"
SIDES :	12"
REAR :	12"
VENT :	6"

## 3. PROVIDE AIR FOR COMBUSTION AND VENTILATION

Provisions for combustion and ventilation air must be in accordance with section 5.3. "Air for combustion and Ventilation", of the National Fuel Gas Code, ANSI Z223.1, or Sections 7.2, 7.3 or 7.4 of CAN/CGA B149.1 Installation Codes, and applicable provisions of the local building codes.

The operation of exhaust fans, compressors, air handling units etc. can rob air from the room, creating a negative pressure condition leading to reversal of the natural draft action of the venting system. Under these circumstances an engineered air supply is necessary.

If the heater is to be installed near a corrosive or potentially corrosive air supply, the heater must be isolated from it and outside air should be supplied as per code.

Potentially corrosive atmospheres will result from exposure to permanent wave solution, chlorinated waxes and cleaners, chlorine, water softening chemicals, carbon tetrachloride, halogen based refrigerants, Freon cleaning solvents, hydrochloric acid, cements and glues, masonry washing materials, antistatic fabric softeners, dry cleaning solvents, degreasing liquids, printing inks, paint removers, etc.

#### 4. ELECTRICAL WIRING

All electrical wiring to the boiler must be electrically bonded to ground in accordance with the requirements of the authority having jurisdiction or, in the absence of such requirements, with the National Electrical Code, ANSI/NFPA 70 or the Canadian Electrical Code Part I, CSA C22.1, Electrical Code.

Provide disconnecting means of sufficient rating within sight of the boiler. These heaters require an 115-V 60-hz supply. Depending on the pump used, a 15-amp breaker is usually sufficient.

Electrical connections must be made so that the circulator will operate before the gas valve can open. At no time may the control system allow the burner to fire without water flowing in the system.

Use minimum 18-gauge conductor for 24-volt field wiring to boiler. Splicing of wires is not recommended.

Use sealed tight conduit suitable for outdoor use for outdoor installations.

For low water cutoff and remote controller, use terminal strip provided inside control panel.

Refer to wiring diagram provided with boiler.

#### 5. GAS SUPPLY AND PIPING

This boiler is intended to operate at inlet gas pressures not exceeding ½ psi (14" water column). If higher pressures are present, consult the gas company for correction.

When pressure testing the gas supply piping at pressures above ½ psi, the boiler and its individual gas shut-off valve must be disconnected from the supply piping.

Provide a trap (drip leg) as close to the heater as possible.

Install a good joint union and manual shut-off valve in the gas line near the heater to allow easy removal of the gas control assembly.

Provide gas pressures at inlet to boiler gas train as follows:

	PROPANE	NATURAL GAS
Minimum (inches water column)	11	5
Maximum ( inches water column)	11	7

The gas supply line must be of adequate size to prevent undue pressure drop and must never be smaller than the size of the connection on the heater. Sizing based on Table 1 is recommended.

Before operating the boiler, the complete gas train and all connections must be tested using soap solution.

TABLE 1

DISTANCE FROM NATURAL GAS METER OR PROPANE SECOND STAGE REGULATOR						
Input Btu/hr	0-100 FT.		100-200 FT.		200-300 FT.	
	NAT.	L.P.	NAT.	L.P.	NAT.	L.P.
480,000	1¼"	1"	1½"	1¼"	2"	1½"
660,000	1½"	1¼"	2"	1½"	2"	1½"
840,000	2"	1½"	2½"	2"	2½"	2"
1,020,000	2"	1½"	2½"	2"	2½"	2"
1,200,000	2½"	2"	2½"	2"	3"	2½"
1,380,000	2½"	2"	2½"	2"	3"	2½"
1,560,000	2½"	2"	3"	2½"	3"	2½"
1,740,000	2½"	2"	3"	2½"	3"	2½"
1,950,000	2½"	2"	3"	2½"	3"	2½"

## 6. VENTING

Boilers for outdoor installation are intended to vent using a listed vent cap.

The BlueFlame windproof cabinet protects the unit from weather, when fitted with the factory supplied air intake and UL approved vent cap (93-0297), it will be self-venting and suitable for outdoor installation.

1. Outdoor models must be installed outdoors and must use the Air Intake and Vent Cap supplied by Camus Hydronics. Alternately, all listed vent cap may be used along with the Camus supplied air intake
2. Periodically check to ensure that air intake and vent cap are not obstructed.
3. Locate appliance at least 3 feet away from any overhang.
4. Locate appliance at least ten feet from building air intake.
5. Avoid installation in areas where runoff from adjacent building can spill onto appliance.

For outdoor installations, always consider the use of a shelter such as a garden shed in lieu of direct exposure of the appliance to the elements. The additional protection afforded by the shelter will help to minimize nuisance problems with electrical connections and will allow easier servicing of the appliance under severe weather conditions.

For indoor installations the draft hood provided with this boiler must be installed without alteration. Vent installations must be in accordance with Part 7, Venting of Equipment, of the National Fuel Gas Code, ANSI Z223.1, or Section 7, Venting of Equipment and Air Supply for Appliances, of the CAN/CGA B149.1, Installation Codes, and applicable provisions of the local building codes.

Vent connectors serving appliances vented by natural draft shall not be connected into any portion of mechanical draft systems operating under positive pressure.

Horizontal runs of vent pipe shall be securely supported (approximately every 4 feet) to prevent sagging and maintain a minimum upward slope of ¼" per foot from the boiler to the vent terminal.

When an existing boiler is removed from a common venting system, the common venting system is likely to be too large for proper venting of the appliances remaining connected to it .At the time of removal of an existing boiler, the following steps must be followed with each

appliance remaining connected to the common venting system placed in operation, while the other appliances remaining connected to the common venting system are not in operation.

- a) Seal any unused openings in the common venting system.
- b) Visually inspect the venting system for proper size and horizontal pitch and determine that there is no blockage, restriction, leakage, corrosion or other deficiency, which could cause an unsafe condition.
- c) Insofar as is practical, close all building doors and windows and all doors between the space in which the appliances remaining connected to the common venting system are located and other spaces of the building.

Turn on the clothes dryers and any appliances not connected to the common venting system. Turn on any exhaust fans, such as range hoods and bathroom exhausts, so they will operate at maximum speed, do not operate a summer exhaust fan. Close fireplace dampers.

- d) Place in operation the appliance being inspected. Follow the lighting instructions. Adjust thermostat so that appliance operates continuously.
- e) Test for spillage at the draft hood relief opening after 5 minutes of main burner operation. Use the flame of a match or candle or smoke from a cigarette.
- f) After it has been determined that each appliance remaining connected to the common venting system properly vents when tested as outlined above, return doors, windows, exhaust fans, fireplace dampers and any other gas-burning appliance to their previous condition of use.
- g) Any improper operation of the common venting system must be corrected so that the installation conforms to the National Fuel Gas Code, ANSI Z223.1 or CAN/CGA B149, Installation Codes. When resizing any portion of the common venting system, the common venting system should be resized to approach the minimum size as determined using the appropriate tables in Part 11 of the National Fuel Gas Code, ANSI Z223.1 or CAN/CGA B149, Installation Codes.

Heat exchanger surfaces and vent piping should be checked every six months for deterioration and carbon deposits. Remove all soot or other obstructions from the chimney and flue, which might impede draft action. Replace any damaged or deteriorated parts of the venting system.

A qualified service technician should follow this procedure when inspecting and cleaning the heat exchanger and vent pipe.

1. Turn off electrical power and close main manual gas shut-off and allow boiler to cool down
2. Remove the boiler draft diverter and vent pipe running to chimney.
  - Check heat exchanger, vent and chimney for obstruction and clean as necessary.
3. Remove burner tray from boiler and vacuum top heat exchanger and coils.
4. Reinstall parts removed in steps 2 and 3.
  - Be sure that vent pipe has proper pitch and is properly sealed.
5. Restore electrical power and gas supply to boiler.
  - Place boiler in operation using lighting instructions provided.
  - Check for gas leaks and proper vent operation.

Three venting options are available for this boiler. See Figure 1 below for details.

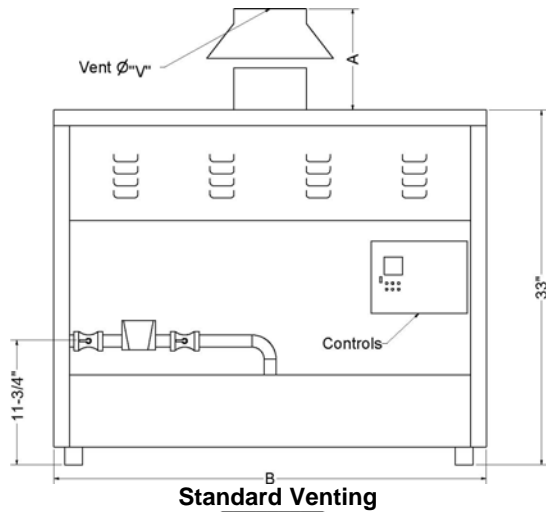

**Standard Venting**

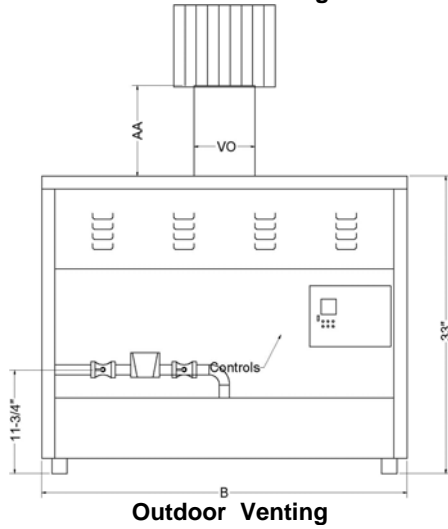

**Outdoor Venting**

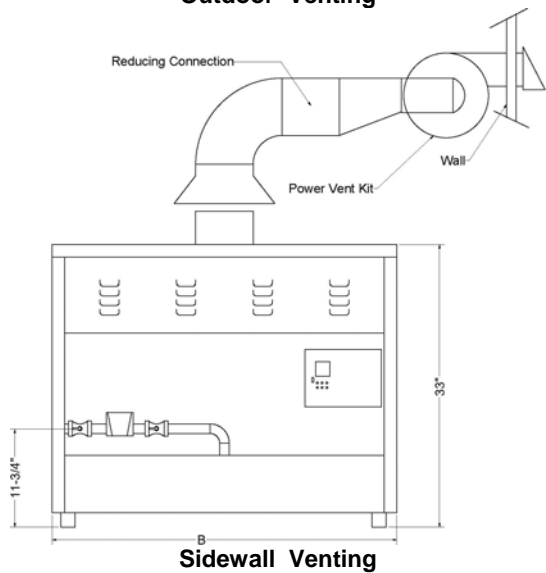

**Sidewall Venting**

Standard Venting						
Model	A	B	V	Nat. Gas	L.P.	
480	16"	30 3/4"	10"	1"	3/4"	
660	16"	39"	12"	1"	3/4"	
840	19"	47 1/4"	14"	1"	3/4"	
1020	21"	55 1/2"	16"	1 1/4"	1"	
1200	21"	63 3/4"	16"	1 1/4"	1"	
1380	21"	72"	18"	1 1/2"	1"	
1560	21"	80 1/4"	18"	1 1/2"	1"	
1740	21"	88 1/2"	20"	1 1/2"	1 1/4"	
1950	21"	96 3/4"	20"	1 1/2"	1 1/4"	

Outdoor Venting						
Model	AA	B	VO	Nat. Gas	L.P.	
480	15"	30 3/4"	12"	1"	3/4"	
660	15"	39"	14"	1"	3/4"	
840	15"	47 1/4"	16"	1"	3/4"	
1020	20"	55 1/2"	18"	1 1/4"	1"	
1200	20"	63 3/4"	18"	1 1/4"	1"	
1380	20"	72"	20"	1 1/4"	1"	
1560	20"	80 1/4"	20"	1 1/4"	1"	
1740	20"	88 1/2"	22"	1 1/2"	1 1/4"	
1950	20"	96 3/4"	22"	1 1/2"	1 1/4"	

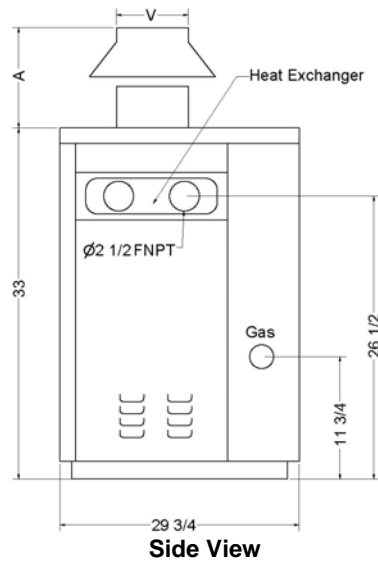

**Side View**

Figure 1



## 7. SAFETY DEVICES

### 7.1 WATER FLOW SWITCH (shipped loose)

A water flow switch is shipped loose and is to be installed in the outlet piping on all heating boilers and hot water supply boilers. The flow switch is wired in series with the 24VAC safety control circuit. A diagnostic light will be indicated on the control display on a low flow condition.

### 7.2 LOW WATER CUTOFF (If Equipped)

If this boiler is installed above radiation level, a low water cut-off device must be installed at the time of boiler installation. Some local codes require the installation of a low water cut-off on all systems. Electronic low water cut-offs are available as a factory supplied option on all models. Low water cut-offs should be tested every six months. The normally open switch contact of the low water cutoff is to be wired in series with the flow switch. A diagnostic light will be indicated on the control display on a low flow condition. Caution: remove jumper when connecting to 24 VAC circuit.

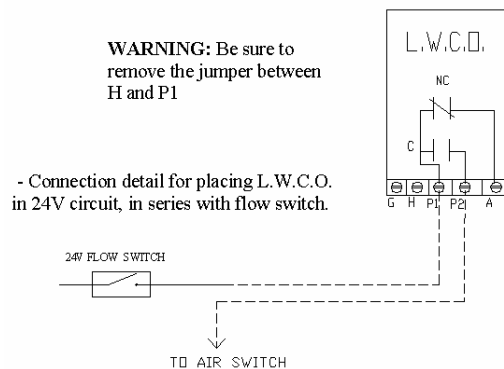

### 7.3 RELIEF VALVE (shipped loose)

This appliance is supplied with a relief valve sized in accordance with ASME Boiler and Pressure Vessel Code, Section IV ("Heating Boilers"). The relief valve is to be installed in the vertical position and mounted in the hot water outlet. No valve is to be placed between the relief valve, and the appliance. To prevent water damage, the discharge from the relief valve shall be piped to a suitable floor drain for disposal when relief occurs. No reducing couplings or other restrictions shall be installed in the discharge line. The discharge line shall allow complete drainage of the valve and line. Relief valves should be manually operated at least once a year.

## 8. FREEZE PROTECTION

Boiler installations are not recommended in areas where the danger of freezing exists unless precautions are taken. Maintaining a mixture of 50% water and 50% propylene glycol is the preferred methods of freeze protection in hydronic systems. This mixture will protect the boiler to approximately -35 °F (-37 °C). To maintain the same temperature rise across the boiler increase the G.P.M. flow by 15% and the head loss by 20%.

A snow screen should be installed to prevent snow and ice accumulation around the boiler. Regular inspections should be made to ensure that air intake and vent are free of snow and ice.

## 9. WARNING REGARDING CHILLED WATER SYSTEMS

When a boiler is connected to an air conditioning system where the same water is used for heating and cooling, the chiller must be piped in parallel with the boiler. Appropriate flow control valves; manual or motorized must be provided to prevent the chilled water from entering the boiler. (See figure 2)

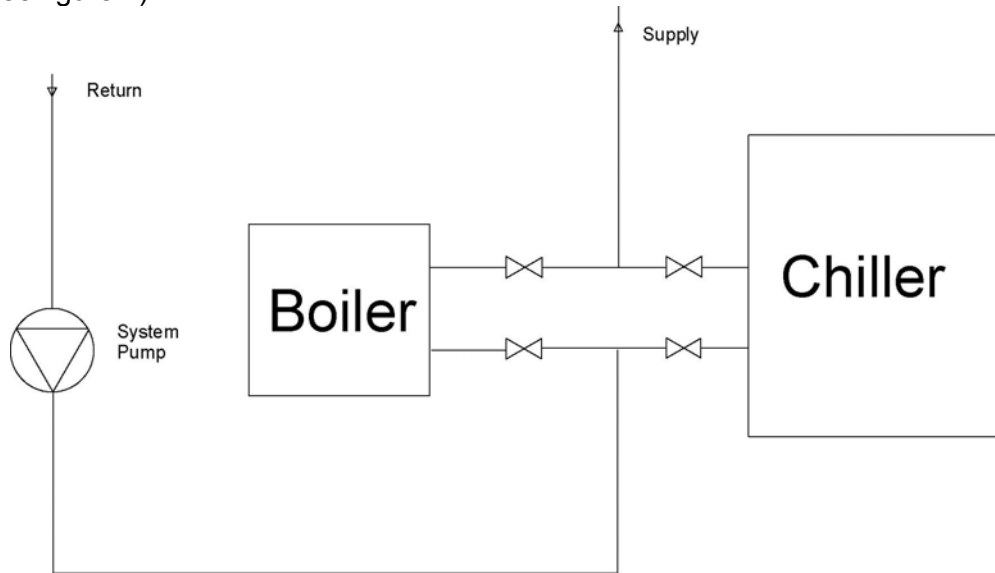

Figure 1

When a boiler is connected to heating coils located in air handling units (where they may be exposed to refrigerated air circulation), the boiler piping system shall be equipped with a flow control valve or other automatic means to prevent gravity circulation of chilled water through the boiler. Chilled water in the boiler will create condensate on the boiler tubes, which will collect in the combustion chamber causing corrosion.

## 10. PIPING OF BOILER TO THE SYSTEM (FIG.3)

Check all applicable local heating, plumbing and building safety codes before proceeding.

Be sure to provide unions and gate valves at inlet and outlet to boiler so that it can be easily isolated for service.

This boiler is of a low mass design, which provides for instant heat transfer. Special attention to water flow rates will ensure that temperature rise does not exceed 35 °F (19.4 °C). The following table 2 is provided as a guide.

For application in areas known to have hard water conditions, contact factory for recommendations.

TABLE 2

Model	20°F (11°C) TEMP RISE		30°F (16.7°C) TEMP RISE		35°F (19.4°C) TEMP RISE	
	U.S G.P.M.	ΔP ft.	U.S G.P.M.	ΔP ft.	U.S G.P.M.	ΔP ft.
BF 480	40.0	0.5	26.5	0.3	22.5	0.2
BF 660	55.0	1.1	36.5	0.5	31.0	0.4
BF 840	70.0	2.1	46.5	0.9	40.0	0.7
BF 1020	85.0	3.3	56.5	1.5	48.5	1.2
BF 1200	❖	❖	66.5	2.3	57.0	1.7
BF 1380	❖	❖	76.5	3.3	65.5	2.5
BF 1560	❖	❖	86.0	4.5	74.0	3.4
BF 1740	❖	❖	96.0	5.9	82.0	4.5
BF1950	❖	❖	108.0	6.8	92.5	6.0

❖ Contact Camus for recommendation

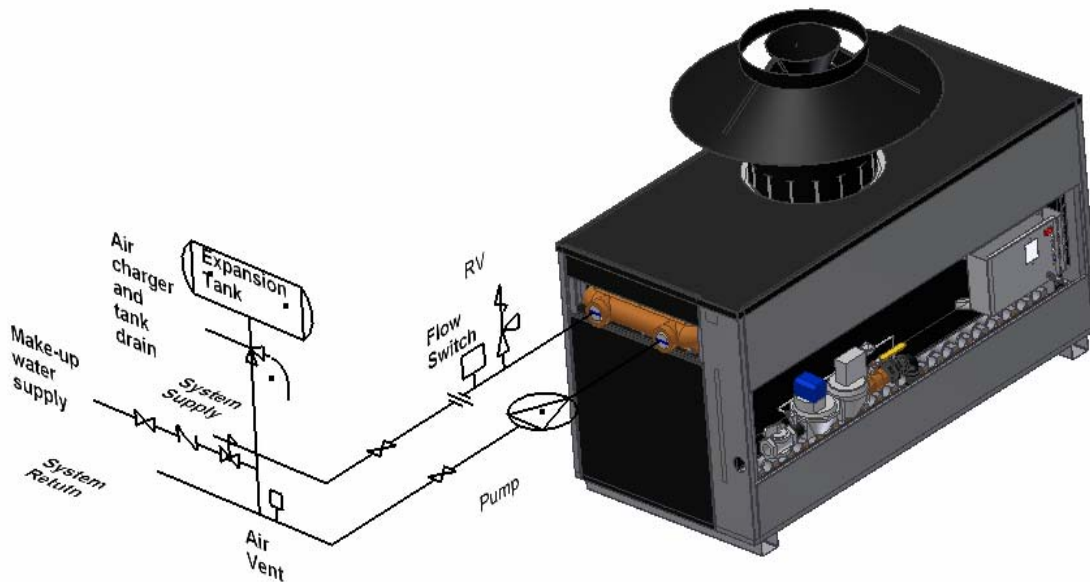

Figure 3

If the boiler is installed above radiation level, it must be provided with a low water cutoff device at the time of boiler installation. (Available from factory)

To eliminate trapped air, install venting devices at high points in the system as well as in the piping on the suction of the pump and in the piping on the discharge of the boiler.

Use suitable pipe hangers or floor stands to support the weight of all water and gas piping.

Do not allow the boiler to run with inlet water temperature below 110°F.

The boiler must be installed so that the gas ignition system components are protected from water (dripping, spraying, rain, etc.) during appliance operation and service (circulator replacement, control replacement, etc.)

## **11. PLACING BOILER IN OPERATION**

The Blue-Flame boiler should be installed and started up by qualified personnel.

With the boiler off, open makeup water valve and allow system to fill slowly. Adjust the pressure regulator to provide at least 15 psig at the highest point in the system.

With all air vents open, run system circulating-pump for a minimum of 30 minutes with the boiler off.

Open all strainers in the circulating system and check for debris.

Check liquid level in expansion tank. With system full of water at 15 psig, the level of water in the expansion tank should not exceed 1/4 of the total volume with the balance filled with air.

Start up boiler following instructions provided. Operate entire system including pumps and radiation for at least 1 hour.

Check water level in expansion tank. If level exceeds 1/2 of tank volume, air is still trapped in system. Shut down boiler and continue to run pumps.

Within 3 days of start up, recheck all air vents and expansion tank as described above.

## **12. CHECK OUT OF IGNITION SYSTEM SAFETY SHUT-OFF DEVICE**

After initial fill while the main burner is firing, shut off gas to the pilot and clock the time taken for the main gas valve to shut down. If the safety control is functioning properly, power to the gas valve will be shut off within 4 seconds of the pilot gas being shut off. If shut down takes longer, ignition control or gas valve may be defective.

## **13. LOW WATER TEMPERATURE SYSTEMS**

In applications where the heating system requires supply water temperatures below 110°F, a bypass line must be installed upstream of the boiler pump so that outlet water can be re-circulated to raise the inlet temp to a minimum of 110°F. Balancing valves, preferably globe valves are used to adjust flow. (See figure 4)

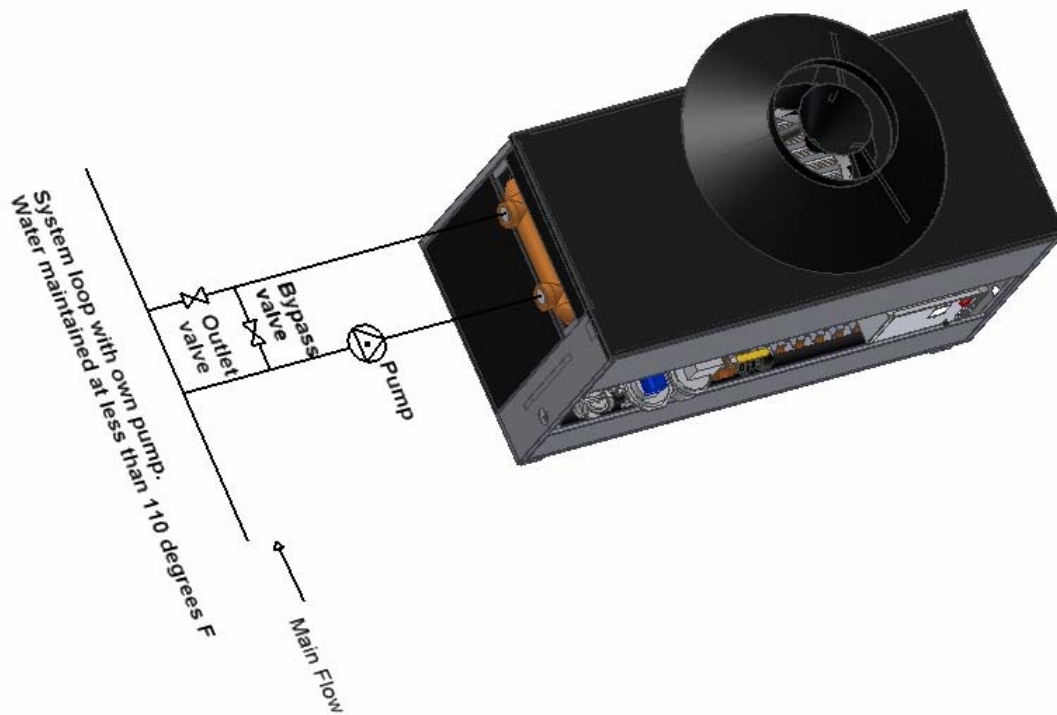

Figure 4

- Adjustment procedure.
  - a) Fully open bypass and outlet valves.
  - b) With boiler running, read the inlet temperature after 15 minutes.
  - c) If the inlet temperature is less than 110 °F slowly close outlet valve until the inlet temperature climbs to 110 °F
  - d) If the inlet temperature is greater than 110°F but not greater than 140 °F no further adjustment is required.
  - e) Check the inlet temperature after 5 minutes and make final adjustments.

## 14. INSTANTANEOUS WATER HEATER

An instantaneous water heater is designed to deliver hot water without the use of a storage tank. It is suitable for applications with variable load such as restaurants, condominiums, apartments and motels. (See figure 5) Call Camus for further recommendations.

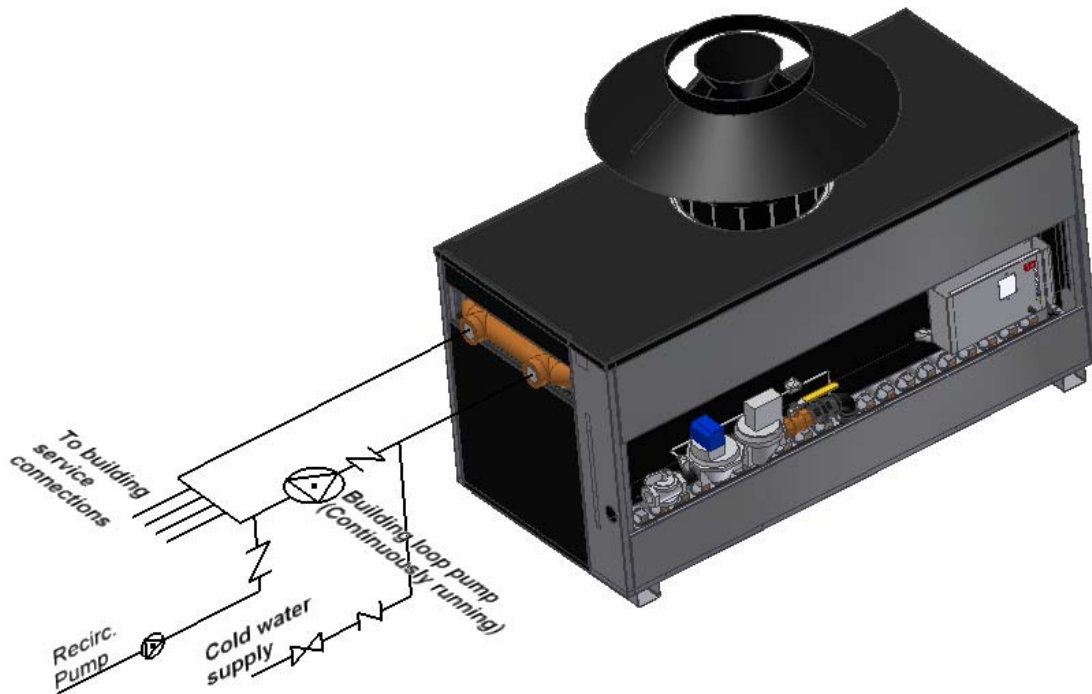

Figure 5

## 15. PILOT AND MAIN BURNER FLAMES

To maintain safe operation and the greatest efficiency of the boiler, check the main burner and pilot burner every six months for proper flame characteristics.

### 15.1. MAIN BURNER

The main burner, figure 6 should display the following characteristics;

- Acceptable CO and CO<sub>2</sub> levels for complete combustion.
- Light off smoothly.
- Reasonably quiet while running.
- Stable flame with minimum of lifting.
- Blue flame with natural gas, yellow tips with propane gas

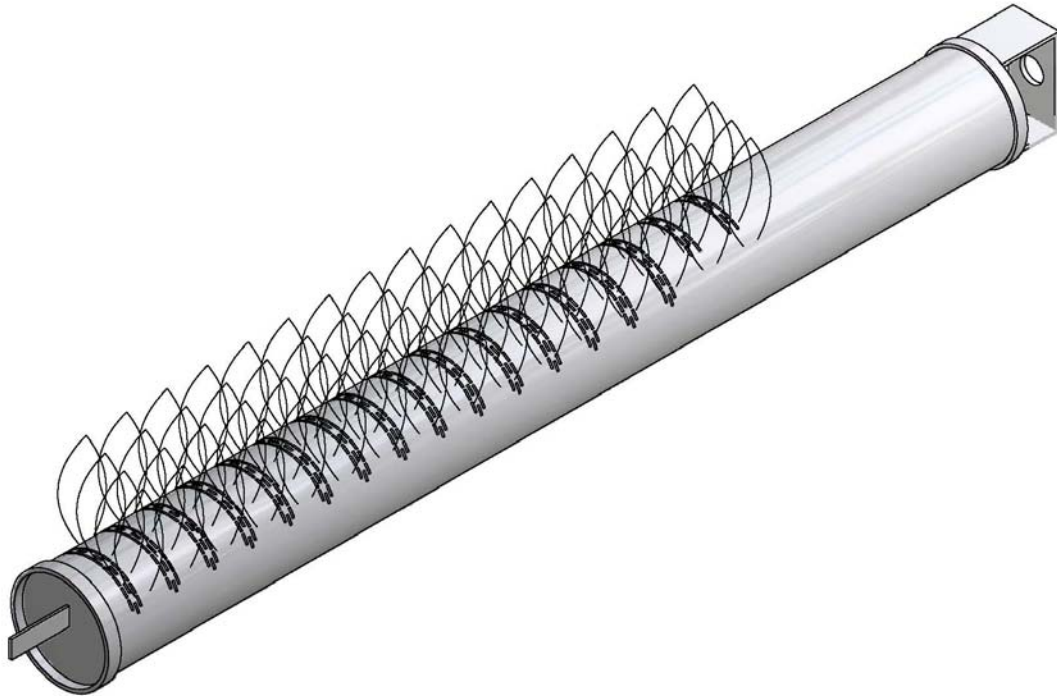

Figure 6

If burner characteristics do not match the above, check for accumulation of lint and other foreign material at burner air inlets.

A qualified service technician should follow this procedure when burners need cleaning.

1. Shut off power and close main manual gas valve.
  - Allow burners to cool before removal.
2. Loosen union and remove main burner tray assembly from boiler.
3. Remove and thoroughly clean burners. Check all ports and air channels for blockage.
4. Reinstall the burners.
5. Restore electrical power and gas supply to the boiler.
  - Following the lighting instructions put the boiler back into operation
  - Check for gas leaks and proper boiler and vent operation.

## 15.2. PILOT BURNER

Turn the gas valve control knob counterclockwise to off position and allow the boiler to try for ignition. Observe the spark making sure that it is strong and continuous.

If the spark is not acceptable the igniter will have to be removed. This can be readily accomplished by first removing the burners tray assembly from the boiler as detailed in 15.1.

The spark gap should be 1/8" to 3/16". Make sure that the electrode does not appear overheated or fouled with carbon. It may be necessary to clean the ignition electrode using sandpaper. Once the pilot appears to be properly set, reinstall it into the boiler making sure to properly tighten the pilot line connection.

Once the spark is satisfactory, open the pilot gas and allow the pilot burner to light. Once air has been purged from the pilot line, the pilot flame should appear almost instantly at the initiation of spark. Cycle the pilot several times to confirm reliability. A properly set pilot will appear blue and will engulf the ignition sensor and ground plate. (See figure 7)

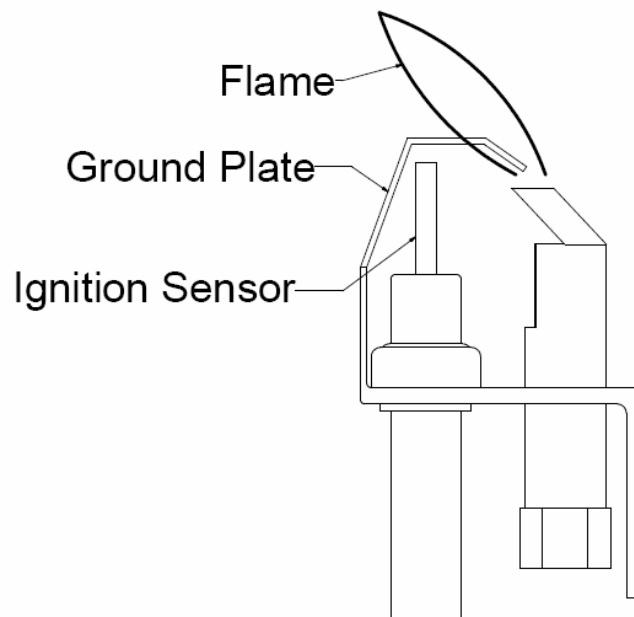

Figure 7

Turn the gas control to "ON" and allow the main burner to light. The pilot must not extinguish. After running for 15 minutes, cycle the boiler to ensure that the pilot remains stable.



## 16. OPERATION AND SERVICE

### OPERATION:

Before operating the boiler, the entire system must be filled with water, purged of air and checked for leaks. Do not use Stop leak or other boiler compounds. The gas piping must also be leak tested.

Any safety devices including low water cutoff, flow switch and high limit used in with this boiler must receive periodic inspection (every six months) to assure proper operation. a low water cutoff of the float type should be flushed every six months. All relief valves should be inspected and manually operated every six months.

For your safety follow the lighting and operating instructions below and on the boiler. To turn on main burners, slowly turn manual main gas on after pilot is established.

Set primary system controller to desired temperature.

To turn off boiler close main manual gas valve, close pilot manual valve and turn off electric power to system.

### SERVICE:

Disconnect main power and turn off gas supply before servicing unit.

To remove and clean the burners follow the detailed procedure in section 15 of this manual.

After the first season of operation inspect the heat exchanger and venting. Follow the detailed instructions in section 6 of this manual.

**CAUTION:** Label all wires prior to disconnection when servicing controls. Wiring errors can cause improper and dangerous operation. Verify proper operation after servicing.

Any audible sounds in the equipment, like pinging, crackling or hissing are indications of scaling or lack of sufficient water flow. Under these conditions the boiler must be shut down immediately and the heat exchanger and coils checked for damage. If the exchanger is damaged from scaling, it is not covered by warranty.

Should your equipment be subjected to fire, flood or some other unusual condition, turn off all gas and electrical supply. If you are unable to turn off the gas, call your gas company or gas supplier at once. Do not put the unit back in operation until it has been checked by a qualified agency to ensure that all controls are functioning properly.

Units that are not operated for a period of 60 days or more are considered seasonal operations. It is recommended that before returning one of these units to service, the proper operation of all controls be checked by a qualified service technician.

## **17. LIGHTING INSTRUCTIONS**

1. Turn off electric power to boiler.
2. Close main manual valve and main firing valve and wait 5 minutes.
3. Set primary system controller to desired temperature.
4. Set main manual valve to pilot position.
5. Turn on electric power to boiler. The electrode at the pilot should begin to spark. This can be observed with a mirror. The pilot valve will open to permit gas flow to the pilot.
6. There is a 15 second trial for ignition, which is enough time to light the pilot if air is not present in the pilot line. If pilot fails to light and you suspect air in the line, close the main manual valve and repeat lighting steps 1 thru 5.
7. Once the pilot lights it should envelope the ignition rod and ground strap. Removing the pilot regulator cover and turning the adjustment screw can adjust the pilot.
8. Open the main firing valve to allow gas to reach the main burners. If the main burners fail to ignite, turn the main firing valve off to see if the pilot is burning. If not, repeat lighting procedure steps 1 thru 7.

TO TURN OFF BOILER: Close main manual valve and main firing valve and turn off electric power to system.

## 18. TROUBLE SHOOTING GUIDE

SYMPTOM	SOLUTION
1. Power light is not lit when switch is flipped to "ON"	<ul style="list-style-type: none"> <li>• Check wiring to switch.</li> <li>• Check circuit breaker</li> <li>• Check fuse</li> </ul>
2. Water flow light remains off.	<ul style="list-style-type: none"> <li>• Ensure that pump is running</li> <li>• Check wiring to flow switch</li> </ul>
3. Pilot sparks but does not light	<ul style="list-style-type: none"> <li>• Make sure that main manual valve is open</li> <li>• Follow lighting instructions to bleed air out of pilot line.</li> <li>• Remove pilot burner and inspect for moisture or dirt in pilot or in pilot line.</li> </ul>
4. Pilot lights momentarily, goes out and then sparks again repeatedly	<ul style="list-style-type: none"> <li>• Observe pilot for proper flame. Adjust if necessary</li> <li>• Remove pilot and ensure that spark electrode is clean and properly located.</li> </ul>
5. Pilot lights but main burner does not fire.	<ul style="list-style-type: none"> <li>• Ensure that main firing valve is in "OPEN" position</li> <li>• Check wiring to valve from ignition control.</li> </ul>
6. Main burner lights but cycles off after a few minutes	<ul style="list-style-type: none"> <li>• Make sure that high limit is set high enough to prevent short cycling.</li> <li>• Adjust pilot pressure for steady flame</li> <li>• Remove pilot and clean ignition sensor.</li> </ul>
7. Boiler starts to whine as the temperature rise increases.	<ul style="list-style-type: none"> <li>• Make sure that all air is bled from system.</li> <li>• Make sure that the static pressure in cold system is at least 15 psig.</li> <li>• Check temperature rise across boiler to ensure adequate water flow.</li> <li>• If necessary, increase static water pressure and decrease gas pressure.</li> </ul>

## 19. TYPICAL GAS TRAIN

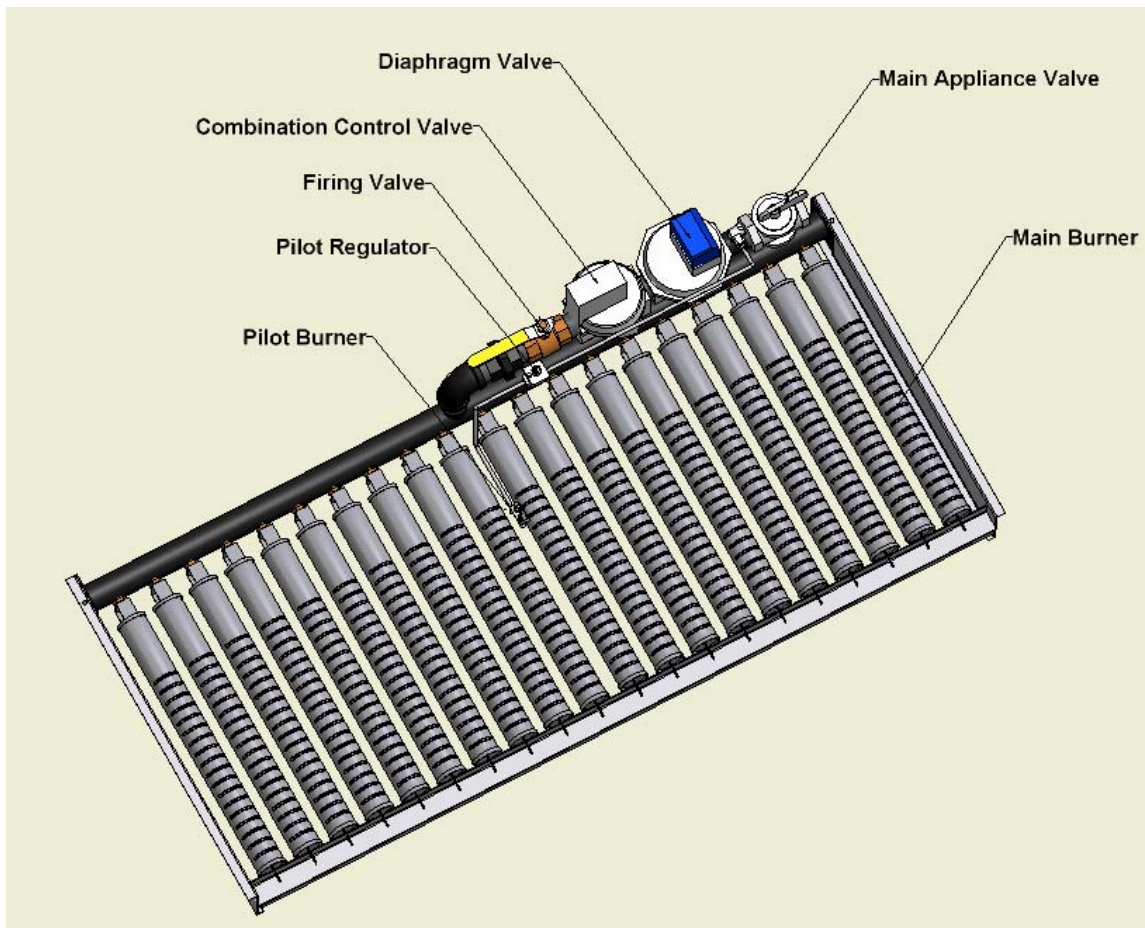

## 20. ELECTRICAL DIAGRAMS

Each Blue-Flame boiler will be provided with its own wiring diagram to guarantee that any options ordered with the unit are properly detailed.

The following diagrams 99-5020 and 99-5021 are provided as typical samples only.



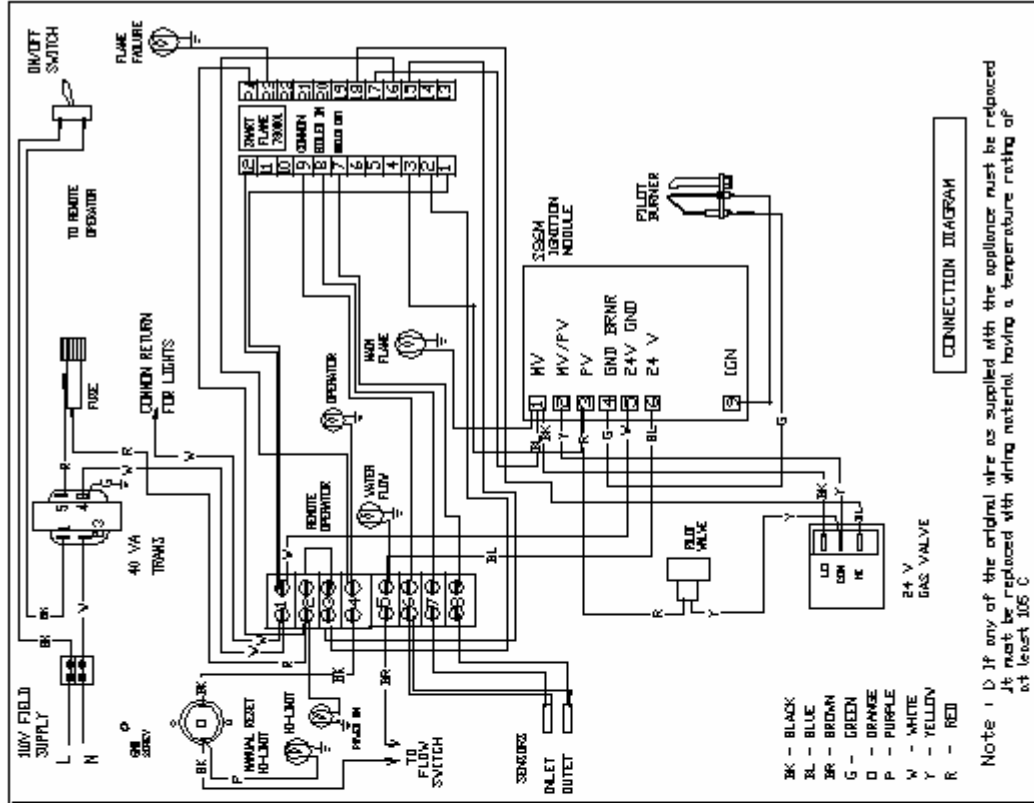

Note: 1. If any of the original wire as supplied with the appliance must be replaced it must be replaced with wiring material having a temperature rating of at least 105°C

CONNECTION DIAGRAM

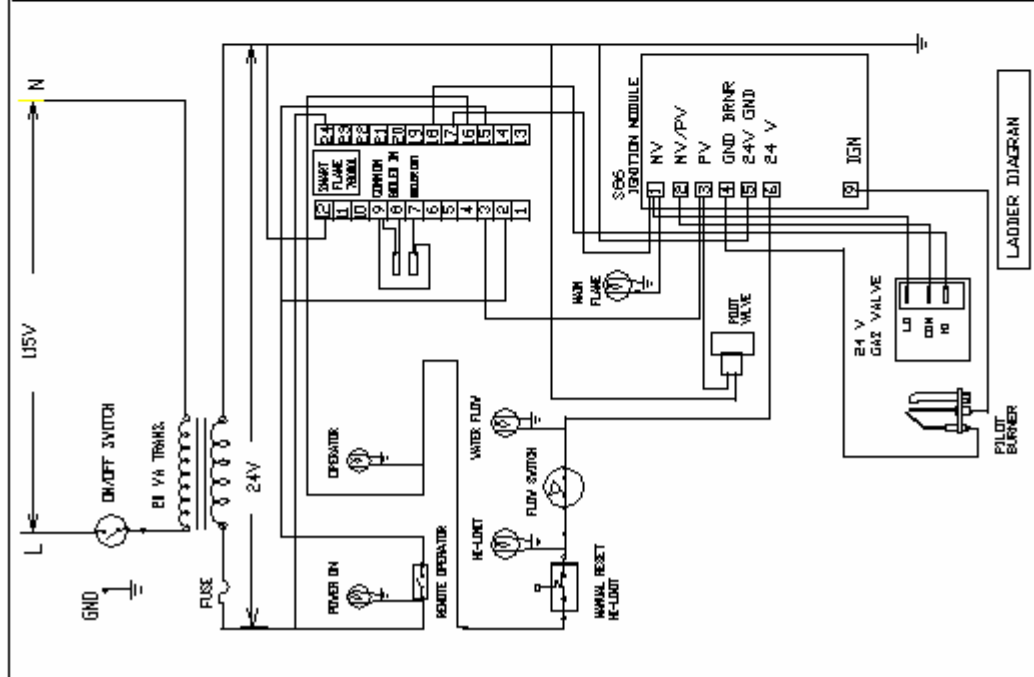

LADDER DIAGRAM

DESC:	BLUEFLAME SS6M SPARK IGNITION , 2 stages, MODEL 840 TO 1950	DATE :	07/25/03	SCALE :	1 NTS
	CAMUS HYDRONICS LTD.	DR :	C.P.	DWG:	99-5021 REV-0

## 21. EXPLODED VIEW

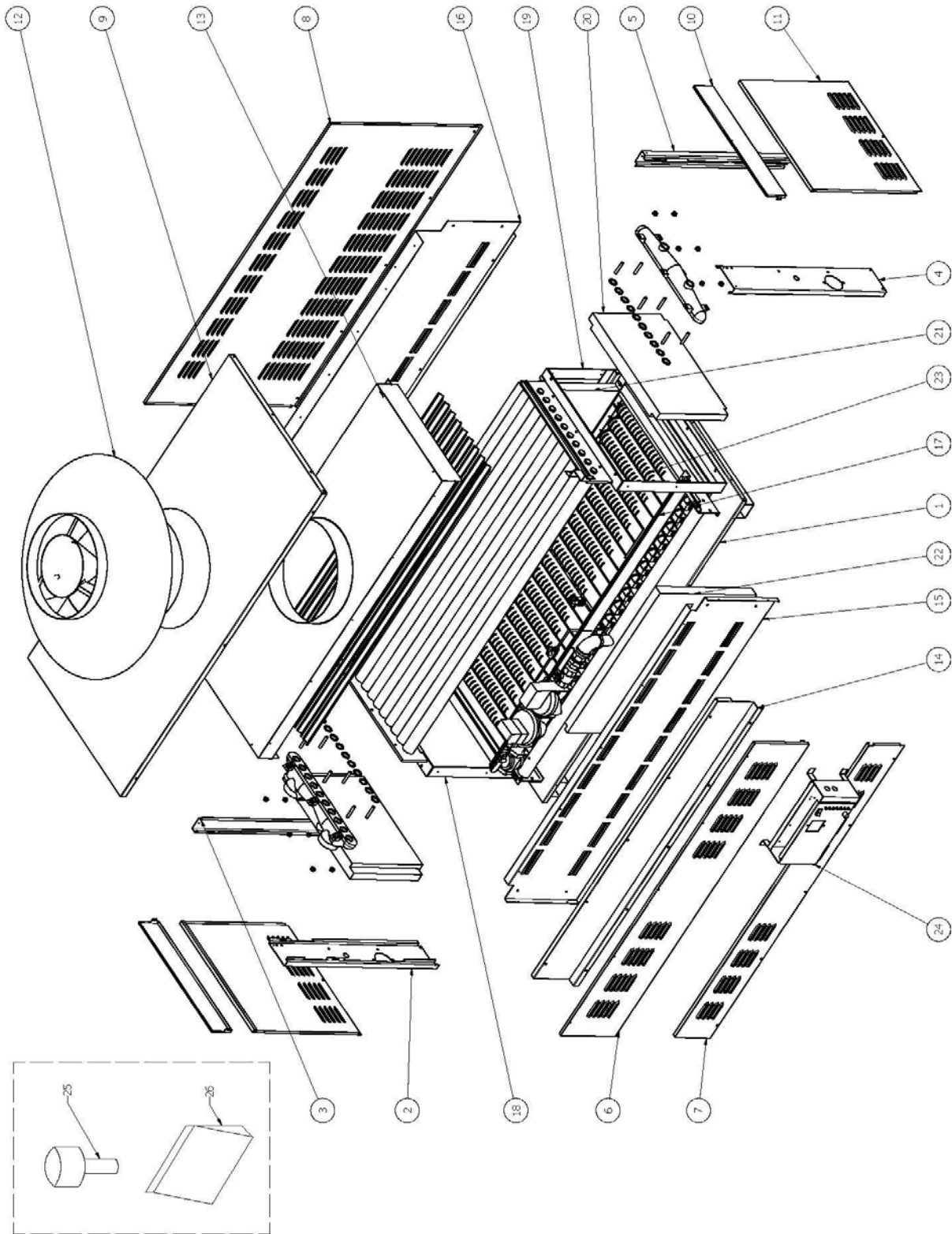

## 22. BLUE FLAME REPLACEMENT PARTS LIST

Key Item #	Description	Model									
		480	660	840	1020	1200	1380	1560	1740	1950	
<b>Outer Jacket</b>											
1	Base Panel Assembly	14-0133-01	14-0133-02	14-0133-03	14-0133-04	14-0133-05	14-0133-06	14-0133-07	14-0133-08	14-0133-09	
2	Left Front Post	14-0234	14-0234	14-0234	14-0234	14-0234	14-0234	14-0234	14-0234	14-0234	
3	Left Rear Post	14-0235	14-0235	14-0235	14-0235	14-0235	14-0235	14-0235	14-0235	14-0235	
4	Right Front Post	14-0236	14-0236	14-0236	14-0236	14-0236	14-0236	14-0236	14-0236	14-0236	
5	Right Rear Post	14-0237	14-0237	14-0237	14-0237	14-0237	14-0237	14-0237	14-0237	14-0237	
6	Front Panel Top	14-0238-01	14-0238-02	14-0238-03	14-0238-04	14-0238-05	14-0238-06	14-0238-07	14-0238-08	14-0238-09	
7	Front Panel Bottom	14-0239-01	14-0239-02	14-0239-03	14-0239-04	14-0239-05	14-0239-06	14-0239-07	14-0239-08	14-0239-09	
8	Rear Panel	14-0222-01	14-0222-02	14-0222-03	14-0222-04	14-0222-05	14-0222-06	14-0222-07	14-0222-08	14-0222-09	
9	Top Panel	14-0211-01	14-0211-02	14-0211-03	14-0211-04	14-0211-05	14-0211-06	14-0211-07	14-0211-08	14-0211-09	
10	Side Panel Top Closure	14-0165	14-0165	14-0165	14-0165	14-0165	14-0165	14-0165	14-0165	14-0165	
11	Side Panel Bottom Closure	14-0163	14-0163	14-0163	14-0163	14-0163	14-0163	14-0163	14-0163	14-0163	
<b>Inner Jacket</b>											
12	Draft Hood	14-0092-01	14-0092-02	14-0092-03	14-0092-04	14-0092-05	14-0092-06	14-0092-07	14-0092-08	14-0092-09	
13	Flue Collector	14-0177-01	14-0177-02	14-0177-03	14-0177-04	14-0177-05	14-0177-06	14-0177-07	14-0177-08	14-0177-09	
14	Heat Exchanger Access Panel	14-0188-01	14-0188-02	14-0188-03	14-0188-04	14-0188-05	14-0188-06	14-0188-07	14-0188-08	14-0188-09	
15	Inner Front Panel	14-0112-01	14-0112-02	14-0112-03	14-0112-04	14-0112-05	14-0112-06	14-0112-07	14-0112-08	14-0112-09	
16	Inner Rear Panel	14-0153-01	14-0153-02	14-0153-03	14-0153-04	14-0153-05	14-0153-06	14-0153-07	14-0153-08	14-0153-09	
<b>Support</b>											
17	Front & Rear Refractory Support Beam	14-0301-01	14-0301-02	14-0301-03	14-0301-04	14-0301-05	14-0301-06	14-0301-07	14-0301-08	14-0301-09	
18	Heat Exchanger Support Frame - Left	16-0017	16-0017	16-0017	16-0017	16-0017	16-0017	16-0017	16-0017	16-0017	
19	Heat Exchanger Support Frame - Right	16-0001	16-0001	16-0001	16-0001	16-0001	16-0001	16-0001	16-0001	16-0001	
<b>Refractory</b>											
20	End Tile	17-0031	17-0031	17-0031	17-0031	17-0031	17-0031	17-0031	17-0031	17-0031	
21	Rear Tile Set	17-0034-01	17-0034-02	17-0034-03	17-0034-04	17-0034-05	17-0034-06	17-0034-07	17-0034-08	17-0034-09	
22	Front Tile Set - Lower	17-0045-01	17-0045-02	17-0045-03	17-0045-04	17-0045-05	17-0045-06	17-0045-07	17-0045-08	17-0045-09	
<b>Burner</b>											
23	Burner Tray Assembly	66-0080-01	66-0080-02	66-0080-03	66-0080-04	66-0080-05	66-0080-06	66-0080-07	66-0080-08	66-0080-09	
<b>Electrical</b>											
24	Electrical Control Box	14-0200	14-0200	14-0200	14-0200	14-0200	14-0200	14-0200	14-0200	14-0200	
<b>Outdoor Jacket</b>											
25	Outdoor Vent Cap	14-0240-01	14-0240-02	14-0240-03	14-0240-04	14-0240-05	14-0240-06	14-0240-07	14-0240-08	14-0240-09	
26	Outdoor front Panel Louver	14-0241-01	14-0241-02	14-0241-03	14-0241-04	14-0241-05	14-0241-06	14-0241-07	14-0241-08	14-0241-09	



## WARRANTY

### GENERAL

Camus Hydronics Limited ("Camus") extends the following LIMITED WARRANTY to the owner of this appliance, provided that the product has been installed and operated in accordance with the Installation Manual provided with the equipment. Camus will furnish a replacement for, or at Camus option repair, any part that within the period specified below, shall fail in normal use and service at its original installation location due to any defect in workmanship, material or design. The repaired or replacement part will be warranted for only the unexpired portion of the original warranty. This warranty does not cover failures or malfunctions resulting from: (1) Failure to properly install, operate or maintain the equipment in accordance with Camus' manual; (2) Abuse, alteration, accident, fire, flood, foundation problems and the like; (3) Sediment or lime buildup, freezing, or other conditions causing inadequate water circulation; (4) Pitting and erosion caused by high water velocity; (5) Failure of connected systems devices, such as pump or controller; (6) Use of non-factory authorized accessories or other components in conjunction with the system; (7) failing to eliminate air from, or replenish water in, the connected water system; (8) Chemical contamination of combustion air or use of chemical additives to water.

### HEAT EXCHANGER

If within TEN years after initial installation of the appliance, a heat exchanger shall prove upon examination by Camus to be defective in material or workmanship, Camus will exchange or repair such part or portion on the following pro rated limited warranty. (1) Years one through five - standard warranty (2) Years six through ten - replacement purchase price pro rated at the following schedule: Year six - 60%, Year seven - 65%, Year eight -70%, Year nine - 75% Year ten -80% of the current list price of the current list price This term is reduced to FIVE years if the appliance is used for other than hydronic space heating.

Heat Exchanger shall be warranted for (20) years from date of installation against "Thermal Shock" (excluded, however, if caused by appliance operation at large changes exceeding 150 °F between the water temperature at intake and appliance temperature, or operating at appliance temperatures exceeding 230 °F).

### BURNER

If within ONE year after initial installation of the appliance a burner shall prove upon examination by Camus to be defective in material or workmanship, Camus will exchange or repair such part or portion.

### ANY OTHER PART

If any other part fails within one (1) year after installation, or eighteen (18) months from date of factory shipment based on Camus' records, whichever comes first. Camus will furnish a replacement or repair that part. Replacement parts will be shipped f.o.b. our factory.

### HOW TO MAKE A CLAIM

Any claim under this warranty shall be made directly to Camus Hydronics Limited Canadian Head Office

### SERVICE LABOR RESPONSIBILITY

Camus shall not be responsible for any labour expenses to service, repair or replace the components supplied. Such costs are the responsibility of the owner.

### DISCLAIMERS

Camus shall not be responsible for any water damage. Provisions should be made that in the event of a water/appliance or fitting leak, the resulting flow of water will not cause damage to its surroundings.



Name of Owner	_____	Name of Dealer	_____
Address	_____	Address	_____
	_____		_____
Model No.	_____	Serial No.	_____
Date of Installation:	_____	Date of Initial Operation:	_____

[6226 Netherhart Road, Mississauga, Ontario, L5T 1B7, CANADA](mailto:6226 Netherhart Road, Mississauga, Ontario, L5T 1B7, CANADA)

CAMUS Hydronics is a manufacturer of replacement parts for most copper finned water heaters and heating boilers as well as a

supplier of specialty HVAC products. Our service line is open 24 hours, 7 days a week!

The CAMUS CERTIFIED! Seal assures you that Reliability, Efficiency & serviceability are built into every single unit! For more information



on our innovative products from CAMUS Hydronics Limited, call 905-696-7800 today.



**CAMUS HYDRONICS LTD.**

6226 Netherhart Road, Mississauga, Ontario L5T 1B7  
TEL: 905-696-7800 FAX: 905-696-8801