

INSTALLATION OPERATION AND SERVICE MANUAL



GAS FIRED COMMERCIAL COPPER TUBE BOILERS

DynaFlame SERIES



FOR HYDRONIC HEATING

Models; DFH500, 750, 1100, 1200, 1500, 1750, 2000, 2500, 3000,
3500, 4000, 4500, 5000



HOT WATER SUPPLY

Models; DFW500, 750, 1100, 1200, 1500, 1750, 2000, 2500, 3000,
3500, 4000, 4500, 5000



WARNING:

If the information in these instructions is not followed exactly, a fire or explosion may result causing property damage, personal injury or death

Do not store or use gasoline or other flammable vapours and liquids in the vicinity of this or any other appliance.

WHAT TO DO IF YOU SMELL GAS

- Do not try to light any appliance,
- Do not touch any electrical switch; do not use any phone in your building,
- Immediately call your gas supplier from a neighbour's phone. Follow the gas supplier's instructions,
- If you cannot reach your gas supplier, call the fire department.

Qualified installer, service agency or the gas supplier must perform installation and service.

To the Installer: After installation, these instructions must be given to the end user or left on or near the appliance.

To the End User: This booklet contains important information about this appliance. Retain for future reference.



CAMUS HYDRONICS LTD.

6226 Netherhart Road, Mississauga, Ontario, L5T 1B7

99-0050
Rev. 04

Table of Contents

PART 1	GENERAL INFORMATION	1
1.1	INTRODUCTION	1
1.2	SPECIAL INSTRUCTIONS TO OWNER	1
1.3	CHECKING EQUIPMENT	1
1.4	WHAT THE LIGHTS MEAN ON YOUR CAMUS APPLIANCE	2
1.5	HOW IT OPERATES (SEQUENCE OF OPERATION)	2
1.5.1	IGNITION PROCESS	3
1.5.2	HEAT TRANSFER PROCESS	3
1.5.3	END OF SEQUENCE	3
1.6	CODES	3
1.7	WARRANTY	4
1.8	REMOVAL OF EXISTING APPLIANCE	4
1.9	BOILER ROOM OPERATING CONDITION	5
1.10	INSTALLATION PROCEDURE LOCATION OF UNIT	5
1.11	Clearance from Combustible Material	5
PART 2	VENTING	7
2.1	GENERAL VENTING GUIDE	7
2.1.1	CATEGORY I AND CATEGORY III VENTING	7
2.1.2	Venting Guidelines for Category I and/or III Venting	7
2.1.3	CATEGORY II AND CATEGORY IV VENTING	8
2.1.4	Venting Guidelines for Category II and/or IV Venting	8
2.1.5	APPROVED VENTING MATERIALS	8
2.1.6	VENT TERMINATION CLEARANCES	8
2.1.7	INLET CAP FOR ROOFTOP TERMINATION	8
2.1.8	LOCATION OF A ROOFTOP AIR INLET AND VENT CAPS	8
2.1.9	AIR INLET DAMPER	9
2.1.10	MASONARY CHIMNEY INSULATIONS	9
2.1.11	Vertical Venting Termination	9
2.1.12	COMBINED COMBUSTION AIR INLET	9
2.1.13	DRAIN TEE	9
2.2	CONVENTIONAL VENTING (INDOOR) INSTALLATIONS	10
2.2.1	Air Required For Combustion and Ventilation	10
2.2.2	EXHAUST FANS	10
2.3	OUTDOOR VENTING	11
2.4	THRUWALL VENTING	11
2.4.1	THRUWALL Vent Cap (14-0090) THRUWALL Intake Air Cap (14-0101)	11
2.4.2	Location of A THRUWALL Vent Termination	11
2.4.3	LOCATION OF A "THRUWALL" AIR INLET CAP	12
2.4.4	AIR INLET DAMPER	12
2.4.5	LENGTH OF AIR INLET PIPE	12
PART 3	GAS CONNECTION	12
3.1	GAS CONNECTION	12
3.2	GAS PIPING	13
3.3	INSTALL PIPING	13
3.4	DIFFERENTIAL AIR PRESSURE	13
3.5	GAS MANIFOLD DIFFERENTIAL PRESSURE ADJUSTMENT	13
3.6	CHECKING GAS SUPPLY PRESSURE	14
3.7	CHECKING DIFFERENTIAL AIR AND GAS PRESSURES	14
3.8	GAS TRAIN AND CONTROLS	15
3.9	RATIO GAS VALVE	15
3.10	VENTING OF GAS VALVES AND PRESSURE SWITCHES	15
3.10	BURNER	15
PART 4	WATER CONNECTION	16
4.1	FREEZE PROTECTION	16
4.2	WARNING REGARDING CHILLED WATER SYSTEMS	16
4.3	INLET AND OUTLET CONNECTIONS	17
4.4	MINIMUM PIPE SIZE REQUIREMENTS	17
4.5	PRIMARY HEAT EXCHANGER	17
4.6	LOW WATER TEMPERATURE SYSTEMS (non -condensing)	17
4.7	INSTANTANEOUS WATER HEATER (non-condensing)	18
4.8	CONDENSER HEAT RECOVERY MODULE (CHRM)	18
4.9	CHRM, FLOW and PRESSURE DROP	19
4.10	WATER FLOW SWITCH (shipped loose)	19
4.11	LOW WATER CUTOFF (If Equipped)	19
4.12	RELIEF VALVE (shipped loose)	20
4.13	CONDENSING HEAT RECOVERY MODULE PIPING CONFIGURATIONS	20
4.13.1	CHRM IN SERIES WITH PRIMARY HEAT EXCHANGER (INTEGRATED LOOP)	20
4.14	CIRCULATING PUMP SELECTION	20
4.14.1	CIRCULATING PUMP OPERATION PRIMARY HEAT EXCHANGER	20
4.14.2	CIRCULATING PUMP SELECTION CONDENSOR	20
PART 5	ELECTRICAL & CONTROLS	21
5.1	ELECTRICAL CONECTIONS	21
5.2	VARIABLE FREQUENCY DRIVE (VFD)	21
5.3	DIFFRENTIAL AIR PRESSURE SWITCH	21

5.4	HIGH and LOW GAS PRESSURE SWITCHS (Optional)	21
5.5	HIGH LIMIT	21
5.6	IGNITION CONTROL MODULE	21
5.6.1	SERVICE PARTS	22
5.6.2	IGNITION MODULE LOCKOUT FUNCTIONS	22
5.6.3	DIAGNOSTIC STATUS INDICATION	22
5.6.4	FLAME SENSE TEST	22
PART 6	CONTROL PANEL	23
6.1	APPLIANCE TEMPERATURE CONTROLLER	23
6.2	MODULATING SIGNAL GENERATOR	25
6.3	VARIABLE FREQUENCY DRIVE (VFD)	25
PART 7	COMPONENTS	25
7.1	HOT SURFACE IGNITER (GLOW BAR)	25
7.2	FLAME SENSOR	25
7.3	COMBUSTION AIR FAN	26
7.4	INNER JACKET	26
7.5	OUTER JACKET	26
7.6	VENTING TRANSITION	26
PART 8	FIELD STARTUP PROCEDURE	26
8.1	CHECKING THE INSTALLATION	26
8.2	CHECKING THE CONSTRUCTION	26
8.3	FIRE TESTING	27
8.4	COMISSIONING APPLIANCE	27
PART 9	TROUBLE SHOOTING	28
PART 10	MAINTANANCE	30
10.1	EXAMINE THE VENTING SYSTEM	30
10.2	VISUALLY CHECK MAIN BURNER FLAMES	30
10.3	FLUE GAS PASSAGEWAYS CLEANING PROCEDURES	30
10.4	CONDENSATION TREATMENT	30
10.4.1	CONDENSATE VOLUME	30
10.5	BURNER MAINTENANCE	31
10.5.1	BURNER REMOVAL AND CLEANING	31
10.5.2	BURNER CLEANING PROCEDURE	31
10.6	CHANGING THE HOT SURFACE IGNITER	31
10.6.1	RE-INSTALLING THE IGNITER	32
10.7	PRIMARY HEAT EXCHANGER INSPECTION	32
10.8	CONDENSING HEAT RECOVERY MODULE (CHRM) INSPECTION	32
10.9	RE-INSTALL HEAT EXCHANGERS	32
10.10	COMBUSTION AIR FAN	32
10.11	COMBUSTION AND VENTILATION AIR	32
10.12	CONTROL CIRCUIT VOLTAGE	32
10.13	COMBUSTIBLE MATERIALS	32
10.14	FREEZE PROTECTION	32
10.15	FREEZE PROTECTION FOR A HEATING BOILER SYSTEM (Optional)	33
PART 11	INSTALLATIONS	33
11.1	HEATING BOILER INSTALLATIONS	33
11.2	WATER CONNECTIONS	33
11.3	PIPING LENGTHS	33
11.4	INTERMITTENT PUMP OPERATION	33
11.5	SUMMARY	33
11.6	DOMESTIC HOT WATER HEATER	34
11.7	WATER VELOCITY CONTROL	34
11.8	TEMPERATURE RISE AT FULL FIRING RATE	34
11.9	WATER HEATERS	35
PART 12	EXPLODED VIEW	36
PART 13	ELECTRICAL DIAGRAMS	43
WARRANTY		49

PART 1 GENERAL INFORMATION

1.1 INTRODUCTION

The **DynaFlame** boiler is a fan assisted boiler based on push through design which offers several venting options. Heat output is controlled by a one to one air/gas ratio control gas valve which provides seamless modulation. The boiler provides central heating and/or domestic hot water at working pressure up to 160 PSI. It is designed for use with a fully pumped and pressurized system. The boiler/water heater will automatically modulate to provide heat outputs between 100% to approximately 30% of rated input.

The DynaFlame works on the principle of differential pressure. The operation of the fan will generate a differential pressure, which the gas/air ratio control gas valve will match on the gas side. The steady state efficiency is maintained across the entire range of modulation. Air and gas are metered in precise proportion (1:1 Ratio) to modulation signal, allowing combustion characteristics which determine efficiency to remain the same over entire operating range.

DynaFlame Non-Condensing

In this series most of the sensible heat value is being transferred into the water. The unused portion of the sensible heat and all the latent heat is released through the exhaust vent. The overall efficiency of the DynaFlame is being improved by incorporating preheat of intake combustion air which consequently maintains the outer panels cool and thus reduces jacket loss.

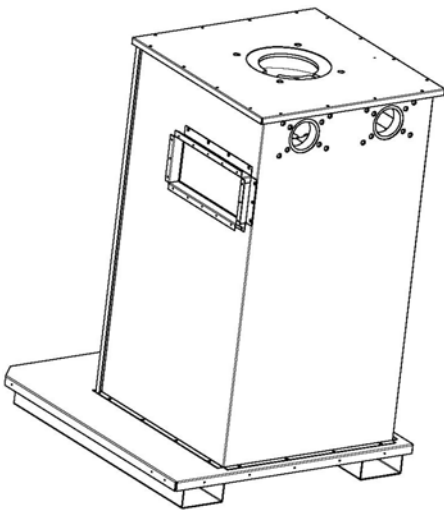

DynaFlame Condensing

In this series most of the sensible heat value is being transferred into the water. The unused portion of the sensible heat and most of the latent heat is absorbed by the Condenser Heat Recovery Module (CHRM).

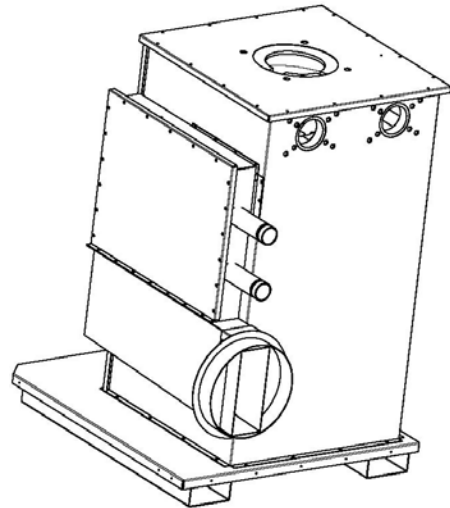

1.2 SPECIAL INSTRUCTIONS TO OWNER

This manual supplies information for the installation, operation and servicing of the appliance. It is strongly recommended that this manual be reviewed completely before proceeding with an installation

CAUTION

It is important that all gas appliances are installed by a competent person. It is in your own interest and that of safety to ensure that all local codes, and all the following "NOTES" and "WARNINGS" is complied with. To Install, service or adjust this appliance, it is imperative that a competent serviceman that is qualified by Camus Hydronics utilize a combustion analyzer with CO₂, CO, and draft gauge, to set the appliance according to Camus Hydronics recommendation, prior to commissioning.

NOTE

RETAIN THIS MANUAL FOR FUTURE REFERENCE

1.3 CHECKING EQUIPMENT

Check for signs of shipping damage upon receiving equipment. Pay particular attention to parts accompanying the boiler, which may show signs of being hit or otherwise being mishandled. Verify total number of pieces shown on packing slip with those actually received. In case there is damage or a shortage, immediately notify carrier.

1.4 WHAT THE LIGHTS MEAN ON YOUR CAMUS APPLIANCE

- POWER Light off means there is no power to the appliance.
- OPERATOR Light on indicates demand for operation (temperature or external control).
- HIGH LIMIT Light off means high limit on back of unit tripped.
- WATER FLOW Light off means no flow/low water level or defective flow switch/low water cutoff.
- AIR FLOW Light off means problem with combustion fan, dirty air filter, blocked vent or fan shut off after 10 minutes in flame failure. If optional low and/or high gas pressure switches are provided it may mean that the appliance has shut off on a gas pressure condition.
- IGNITION TRIAL Light comes on only during start up trials (3 trials standard and single trial for CSD1, for CSD1; to reset push and hold reset button on front of electrical panel until red LED is lit on ignition control).
- MAIN FLAME Lit only when ratio control valve is energized. Valve will open only if proof of closure switch is closed. Indicator in view window shows position of valve stem. Light will stay on only if burner is firing.
- FLAME FAILURE May momentarily light up during ignition trials. If appliance fails to start the fan will shut down, the air flow light will go out and the flame failure light will stay on continuously.

** If the series of lights stops during start up, the next light that is NOT lit identifies where the problem is.

1.5 HOW IT OPERATES (SEQUENCE OF OPERATION)

- 1 The power switch is placed in the "ON" position.
- 2 Minimum 120 VAC 60hz single phase (15A circuit) is supplied to the control junction box models DF-500 through DF-2000 and 120 VAC (20A circuit) models DF-2500 thru DF-3000 and 120/230 VAC 60hz single phase (20A circuit) models DF-3500 through DF-4000 and 120/230 VAC 60hz single phase (30A circuit) models DF-4500 through DF-5000.
- 3 120 VAC power is supplied to the control transformer and Ignition Module on all models.
- 4 24 VAC is supplied to all low voltage controls for all models.
- 5 After the appliance water pump starts, flow is proven by the flow switch. The low water cutoff and flow switch are shipped loose .The flow switch is to be mounted in a tee at the outlet of the appliance. Take care to properly trim the flow switch paddles so as not to jam the switch in the tee. The normally open dry contacts in the low water cutoff (LWCO) are to be wired in series with the normally open contacts of the flow switch. Locate the probe type LWCO in the piping 2 to 3 feet

above the boiler inlet/outlet connection. In all cases check with local codes.

- 6 Local or remote operator calls for heat and operator light illuminates. If the appliance is provided with a local remote switch the local control settings are to be set above the normal maximum expected return water temperature. In this way the local control will not interfere with normal operation of the remote operator and will prevent the appliance from cycling on its limit if the appliance is switched over to local operation due to a failure in the remote operating system.
- 7 The local thermostat initiates a start-up sequence once it receives a heat demand. If the appliance is equipped with a local/remote switch and if the switch is set in remote, a heat demand is available only if the remote system calls for heat.
- 8 The local thermostat energizes the motor stop/start relay which closes the initiate contacts to the variable frequency drive (VFD) which starts to ramp up the frequency to the 230V 3 phase motor of the combustion fan. If the VFD is not in fault mode the frequency will accelerate at the preprogrammed rate towards 60 HZ using the modulating signal provided by the on board modulating control or the remote operating system if a local/remote switch is provided.
- 9 If limit, water flow and airflow lights are lit, the ignition module will receive a 24V signal at terminal 'TH' thru a purple wire. After performing internal self checks the ignition module will energize the amber trial for ignition light and the hot surface igniter at S1 thru a black and brown wire respectively and close the auxiliary fan connections thru two blue wires which will switch a 20 Ω resistor across the modulating signal. This will occur whether the appliance is in remote or local mode. The resistor will case the VFD to see a minimum modulating signal and cause the fan motor to decelerate to the frequency programmed for soft start. The ignition control looks for the set proof current from the igniter (2.7 A +/-0.2).
- 10 If the proof current is not reached the module will stop the ignition sequence after the trial for ignition .The blue main flame light indicating that the main valve is energized will not come on and the appliance will go into lockout. If the proof current is reached the ignition module sends a 24V signal thru a blue wire marked "valve" to the 24/115V interface relay and to the proof demand terminal 3 on the on board smart flame control.
- 11 115V from the 24/115V interface relay will only reach the ratio control valve if the proof of closure (POC) switch in the ratio control valve is closed .If the switch is in an open position the valve stem travel indicator visible thru a view window in the valve will not move even though the blue main flame light will illuminate. This can occur if there is dirt under the valve seat or if the POC switch is defective.
- 12 If the POC switch is initially closed, the blue main flame light will illuminate and the latching relay located in the lower end of the control box allows the 115V signal to the control valve to be uninterrupted when the control valve drives open and the POC switch contacts open.
- 13 After the valve open time (7 or 10 seconds) is ended the ignition module looks for a minimum flame rectification signal of 2 μ A DC from the flame sensor. If the signal is present the ignition module will allow the control valve to remain open, if the ignition module does not see a continuous signal it will shut down the

control valve and will immediately go into lockout mode for CSD1, or proceed to two more trials before locking out in the standard version.

- 14 The ignition module will go into lockout if it does not see the flame rectification signal due to the flame sensor being insulated from oxide deposits or from the sensor rod grounding out due to improper placement or from a damaged ceramic insulator.
- 15 The tip of a properly located sensor rod will be ¾" to 1" away from the burner surface. The µA reading can be conveniently taken at the front of the ignition module at the 'Flame Sense Test' terminals.

1.5.1 IGNITION PROCESS

- 1 The Ignition module supplies voltage to the Air/Gas Ratio Control Valve through proof of closure switch and a latching relay.
- 2 Air/Gas Ratio Control Valve senses the pressure differential between the Combustion Air Fan outlet and the vent outlet and supplies gas to the orifice and into the Fan inlet to pre-mix with air.
- 3 The Gas/Air mixture is forced into the Burner and out of the Burner Ports under pressure at soft start input rate.
- 4 Hot Surface Igniter lights the Gas/Air mixture and the Flame Sensor serves as a means to prove Main Burner Flame by rectification.
- 5 Burner is now firing at soft start input rate.
- 6 Variable Frequency Drive adjusts fan speed based on desired water temperature set point or input signal from remote operator 4-20 mA or 2-10VDC signal (must be specified at time of placing order).
- 7 Burner input rate is variable down to approximately 30% of rate or up to 100% of rate as required to satisfy the set point.

1.5.2 HEAT TRANSFER PROCESS

- 1 Burner Input continues to increase until water temperature reaches the Set Point temperature.
- 2 Burner Input may stabilize at a fixed rate where demand equals input.
- 3 Burner Input will decrease rate when water temperature approaches temperature Set Point.

1.5.3 END OF SEQUENCE

- 1 Set Point temperature is satisfied.
- 2 Power to the gas valves is turned off.
- 3 Combustion Air Fan ramps to a stop over the factory preprogrammed time period of 60 seconds.
- 4 Thermostat is now in a standby mode waiting for the next "Call for Heat".

WARNING

To minimize the possibility of serious personal injury, fire or damage to your appliance, never violate the following safety rules.

WARNING

IMPROPER INSTALLATION, ADJUSTMENT, ALTERATION, SERVICE OR MAINTENANCE can cause injury or property damage. Refer to this manual. For additional information, consult a qualified installer, service agency or gas supplier.

DO NOT

Do not use this appliance if any part of it has been **under water**. The possible damage to a flooded appliance can be extensive and present numerous safety hazards. Any appliance that has been **under water** must be replaced

WHAT TO DO IF YOU SMELL GAS

Do not try to light any appliance. • Do not touch any electric switch: do not use any phone in your building. • Immediately call your gas supplier from a neighbor's phone. Follow the gas supplier's instructions. • If you cannot reach your gas supplier, call the fire department.

IMPORTANT

Consult and follow local Building and Fire Regulations and other Safety Codes that apply to this installation. Contact the local gas utility company to authorize and inspect all gas and flue connections.

Installation and service must be performed by a qualified installer, service agency or the gas supplier.

WARNING

Should overheating occur or the gas supply fails to shut off, **DO NOT** turn off or disconnect the electrical supply to the pump. Shut off the gas supply at a location external to the appliance.

WARNING

Operation of Non-Condensing DynaFlame at low fire (less than 100% of input) for long periods of time will increase the possibility of forming condensation in the flue, particularly in Spring/Fall operation.

- Boilers and water heaters are heat producing appliances. To avoid damage or injury, do not store materials against the appliance or the vent-air intake system. Use proper care to avoid unnecessary contact (especially children) with the appliance and vent-air intake components.
- Never cover your appliance, lean anything against it, store trash or debris near it, stand on it or in any way block the flow of fresh air to your appliance.
- **UNDER NO CIRCUMSTANCES** may flammable materials such as gasoline or paint thinner be used or stored in the vicinity of this appliance, vent-air intake system or any location from which fumes could reach the appliance or vent-air intake system.
- A gas appliance that draws combustion air from the equipment room where it is installed must have a supply of fresh air circulating around it during burner operation for proper gas combustion and proper venting.

1.6 CODES

The equipment shall be installed in accordance with those installation regulations in force in the local area where the installation is to be made. These shall be carefully followed in all cases. Authorities having jurisdiction shall be consulted before installations are made. In the absence of such requirements, the installation shall conform to the latest edition of the National Fuel Gas Code, ANSI Z223.1 and/or CAN/CGAB149 Installation Code. All electrical wiring must be done in accordance with the

requirements of the authority having jurisdiction or, in the absence of such requirements, with national electrical code, ANSI/NFPA70 and/or the Canadian electrical code part 1 CSA C22.1. Where required by the authority having jurisdiction, the installation must conform to American Society of Mechanical Engineers Safety Code for Controls and Safety Devices for Automatically Fired Boilers, ASME CSD-1. All boilers conform to the latest edition of the ASME Boiler and Pressure Vessel Code, Section II. Where required by the authority having jurisdiction, the installation must comply with the CSA International, CAN/CGA-B149 and/or local codes. This appliance meets the safe lighting performance criteria with the gas manifold and control assembly provided, as specified in the ANSI standards for gas-fired units, ANSI Z21.13.

1.7 WARRANTY

- Factory warranty (shipped with unit) does not apply to units improperly installed or improperly operated.
- Factory warranty shall apply only when the appliance is installed in accordance with local plumbing and building codes, ordinances and regulations, the printed instructions provided with it and good industry practices.
- Excessive **water hardness** causing a lime build-up in the copper coils or tubes is not a fault of the appliance and is not covered by warranty. Consult the factory for recommendations for use in hard water areas. (See Water Treatment and Water Chemistry)
- Excessive pitting and erosion on the inside of the copper tube may be caused by too much **water velocity** through the tubes and is not covered by the manufacturer's warranty (See Boiler Flow Rates and Temperature Rise for flow requirements).
- Using or storing **corrosive chemicals** in the vicinity of this appliance can rapidly attack the copper tubes and coils and voids warranty.
- In case of *Condensing* or *Non-Condensing DynaFlame*, The Main (Primary) Heat Exchanger is intended to operate under non-condensing conditions. **Inlet water temperatures** must be maintained at 110°F (64°C) or higher. Warranty is void if the Primary heat exchanger is allowed to operate in condensing mode.
- Damage caused by **freezing or dry firing** voids warranty.
- This appliance is not to be used for **temporary heating** of buildings under construction.
- The manufacturer shall **NOT** be held liable for any personal injury or property damage due to ice formation or the dislodging of ice from the vent system or the vent termination

1.8 REMOVAL OF EXISTING APPLIANCE

When an existing appliance is removed from a common venting system, the common venting system is likely to be too large for proper venting of the appliances remaining connected to it. At the time of removal of an existing appliance, the following steps must be followed with each appliance remaining connected to the common venting system placed in operation, while the other appliances remaining connected to the common venting system are not in operation.

- Seal any unused openings in the common venting system.
- Visually inspect the venting system for proper size and horizontal pitch and determine that there is no blockage, restriction, leakage, corrosion or other deficiency, which could cause an unsafe condition.
- Insofar as is practical, close all building doors and windows and all doors between the spaces in which the appliances remaining connected to the common venting system are located and other spaces of the building. If applicable turn on the clothes dryers and any appliances not connected to the common venting system. Turn on any exhaust fans, such as range hoods and bathroom exhausts, so they will operate at maximum speed. Do not operate a summer exhaust fan. Close fireplace dampers.
- Place in operation the appliance being inspected. Follow the lighting instructions. Adjust thermostat so that appliance operates continuously.
- If provided, test for spillage at the barometric damper relief opening after 5 minutes of main burner operation. Use a cold mirror, the flame of a match, or candle or smoke from a cigarette.
- After it has been determined that each appliance remaining connected to the common venting system properly vents when tested as outlined above, return doors, windows, exhaust fans, fireplace dampers and any other gas-burning appliance to their previous condition of use.
- Any improper operation of the common venting system should be corrected so that the installation conforms to the National Fuel Gas Code, ANSI Z223.1 and/or CAN/CGA B149, Installation Codes. When resizing any portion of the common venting system, the common venting system should be resized to approach the minimum size as determined using the appropriate tables in Part 11 of the National Fuel Gas Code, ANSI Z223.1 and /or CAN/CGA B149, Installation Codes.

Heat exchanger surfaces and vent piping should be checked every six months for deterioration and carbon deposits. Remove all soot or other obstructions from the chimney and flue, which might impede draft action. Replace any damaged or deteriorated parts of the venting system.

A qualified service technician should follow this procedure when inspecting and cleaning the heat exchanger and vent pipe.

1. Turn off electrical power and main manual gas shut-off and allow appliance to cool down.
2. Remove the vent pipe running to the chimney and check heat exchanger, vent and chimney for obstruction and clean as necessary.
3. Remove burner from appliance and carefully clean as required. Never brush or wipe the knitted metal fiber surface, use a garden hose and wash instead.
Caution: Never use pressure washer to clean the burner.
4. Use pressure wash to clean heat exchanger if necessary.
5. Reinstall parts removed in steps 2 and 3. Be sure that vent pipe has proper pitch and is properly sealed.

Replace any damaged gasket. Note that the burner is supplied with two gaskets; a high temperature ceramic paper gasket under the burner flange and a stamped silicon gasket between the burner flange and fan flange. Tighten fan flange mounting nuts to 20 ft-lb.

6. Restore electrical power and gas supply to appliance.
7. Place appliance in operation using lighting instructions provided.
8. Confirm proper operation of all safety devices
9. Check for gas leaks and proper vent operation.

NOTE:
Experience has shown that improper installation or system design, rather than faulty equipment, is the cause of most operating problems

1.9 BOILER ROOM OPERATING CONDITION

- Due to low jacket losses from the appliance, temperatures in typical boiler room may drop significantly; supplemental heat is required to maintain ambient temperature at minimum of 50°F.
- Cold fresh air intakes must be located to minimize the effects on venting and subsequent condensation in the flue of Category I installations. When necessary, consider the use of insulation or corrosion resistant venting material.

1.10 INSTALLATION PROCEDURE LOCATION OF UNIT

Install this appliance in a clean, dry location with adequate air supply and close to a good vent connection.

- Do not locate this appliance in an area where it will be subject to freezing unless precautions are taken. Radiant losses from the DynaFlame are minimal and should not be relied on to keep the appliance room warm. If the appliance is installed in a cold room and/or on a cold floor, isolating the appliance from the cold floor and heating the room is recommended.
- The appliance **must not** be installed on carpeting and should be located close to a floor drain in an area where leakage from the appliance or connections will not result in damage to the adjacent area or to lower floors in the structure, it is recommended that a suitable drain pan, adequately drained, be installed under the unit. Under no circumstances is the manufacturer to be held responsible for water damage in connection with this unit, or any of its components.
- If the appliance is installed above the level of the building's radiation system, a low water cut-off device must be installed in the appliance outlet at a minimum of 3 ft (1M) above the heat exchanger inlet/outlet connections. Some local codes require the installation of a low water cut-off on all systems
- When placing the appliance be aware that a minimum clearance of 24" must be provided at the front to allow easy access to the primary heat exchanger. Non-condensing units do not require access through both sides and could be placed adjacent to each other with zero clearance. For condensing units a minimum clearance of 12" must be provided on the right side for access to the Condensing Heat Recovery Module.
- The appliance must be installed so that the ignition system components are protected from water (dripping, spraying, etc.) during appliance operation and service (circulator replacement, control

replacement, etc.)

- Appliances located in a residential garage and in adjacent spaces that open to the garage and are not part of the living space of a dwelling unit must be installed so that all burners and burner ignition devices have a minimum clearance of not less than 18" (46cm) above the floor. The appliance must be located or protected so that it is not subject to physical damage by a moving vehicle.
- **DO NOT** install this appliance in any location where gasoline or flammable vapors are likely to be present.
- Appliance must be installed on a level floor. Maintain required clearances from combustible surfaces.
- The appliance designed for indoor installation (Indoor Models) must be installed indoors where it is protected from exposure to wind, rain and weather.
- The appliance designed for outdoor installation (Outdoor Models) must be installed outdoors. For outdoor installations, always consider the use of a shelter such as a garden shed in lieu of direct exposure of the appliance to the elements. The additional protection afforded by the shelter will help to minimize nuisance problems with electrical connections and will allow easier servicing of the appliance under severe weather conditions.

1.11 Clearance from Combustible Material

This appliance is suitable for alcove (a closet without a door) installation with minimum clearances to combustibles as follows:

Table 1
Clearances from Combustibles

TOP:	12"
SIDES:	12"
REAR:	12"
VENT:	6"

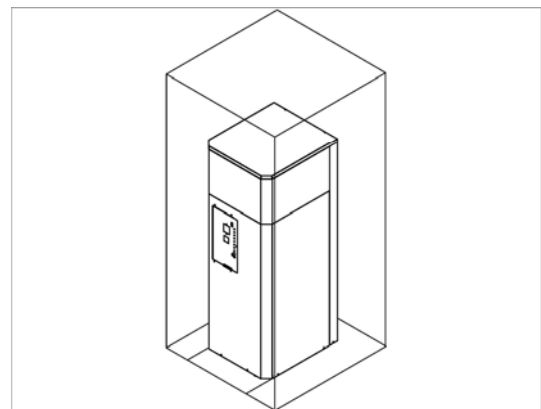

When placing the appliance be aware that a minimum clearance of 24" (60cm) must be provided at the front to allow easy access to the primary heat exchanger.

NOTE: Clearances from combustible construction are noted on the appliance rating plate

Maintain minimum specified clearances for adequate operation. All installations must allow sufficient space for servicing the vent connections, water pipe connections, circulating pump, bypass piping and other auxiliary equipment, as well as the appliance

Table 2

Service Clearances				
Model Numbers	Service Clearance, Inches (cm)			
	Top	Right Side	Left Side	Back
500	24" (60cm)	12" (30cm)	12" (30cm)	*
750	24" (60cm)	12" (30cm)	12" (30cm)	*
1100	24" (60cm)	12" (30cm)	12" (30cm)	*
1200	24" (60cm)	12" (30cm)	12" (30cm)	*
1500	24" (60cm)	12" (30cm)	12" (30cm)	*
1750	24" (60cm)	12" (30cm)	12" (30cm)	*
2000	24" (60cm)	12" (30cm)	12" (30cm)	*
2500	24" (60cm)	12" (30cm)	12" (30cm)	*
3000	24" (60cm)	12" (30cm)	12" (30cm)	*
3500	24" (60cm)	12" (30cm)	12" (30cm)	*
4000	30" (77cm)	12" (30cm)	12" (30cm)	*
4500	35" (89cm)	12" (30cm)	12" (30cm)	*
5000	40" (102cm)	12" (30cm)	12" (30cm)	*

*Allow adequate space for the venting in addition to 6" clearance to combustibles.

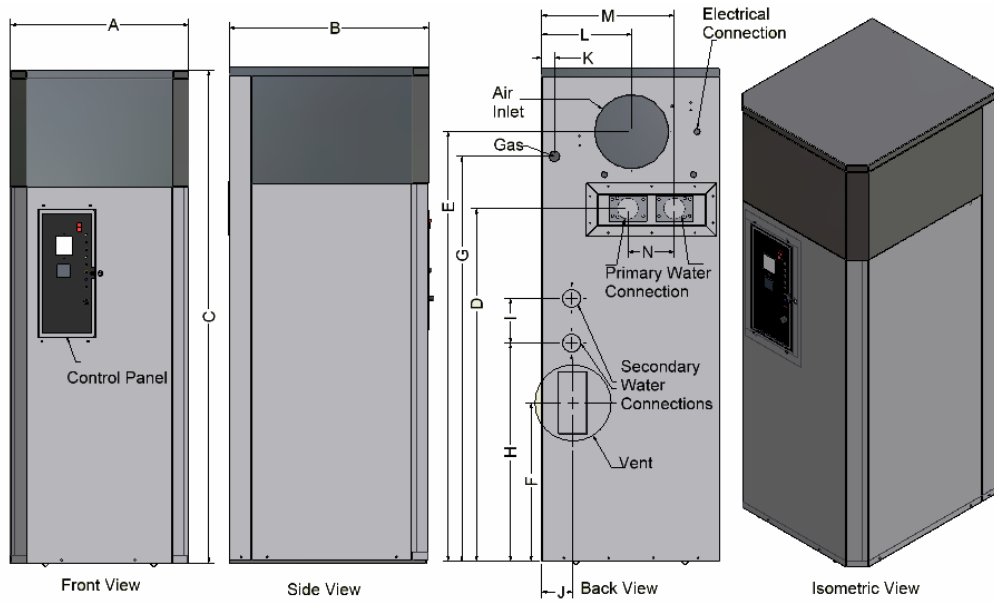

Table 3 – Appliance Dimensions and Specifications

Model	Width Dim. "A"	Depth Dim. "B"	Height Dim. "C"	Water Conn. "D"	Air Inlet "E"	Flue Height "F"	Gas Height "G"	"H"	"I"	"J"	"K"	"L"	"M"	"N"	Vent Dia "V"			Air Inlet Dia. "W"	Water Conn. Prim. †	Water Conn. Second.	Gas Conn.	
															Outdoor	Sidewall	Std.					
500	23"	27"	45"	25¼"	35½"	11"	32¼"	17"	6"	3½"	1½"	10½"	17½"	6½"	8"	6"	6"	8"	6"	2" NPT	1½" NPT	1" NPT
750	23"	27"	54"	34¾"	44½"	12½"	41½"	21"	6"	3½"	1½"	10½"	17½"	6½"	8"	8"	8"	10"	8"	2" NPT	1½" NPT	1" NPT
1100	23"	27"	68"	48½"	58"	19½"	55"	29"	6"	3½"	1½"	10½"	17½"	6½"	8"	8"	10"	8"	2" NPT	1½" NPT	1" NPT	
1200	23"	27"	68"	48½"	58"	19½"	55"	29"	6"	3½"	1½"	10½"	17½"	6½"	8"	8"	10"	8"	2" NPT	1½" NPT	1" NPT	
1500	29½"	34"	57"	38½"	46½"	12½"	43¾"	18"	6"	3½"	1½"	15¼"	23"	10½"	10"	10"	12"	10"	2½" NPT	1½" NPT	1½" NPT	
1750	29½"	34"	61"	41"	51½"	17"	48¾"	22½"	6"	3½"	1½"	15¼"	23"	10½"	10"	10"	12"	10"	2½" NPT	1½" NPT	1½" NPT	
2000	29½"	34"	66"	45½"	55½"	16½"	52¾"	27"	6"	3½"	1½"	15¼"	23"	10½"	12"	12"	14"	12"	3" NPT	1½" NPT	1½" NPT	
2500	29½"	34"	72"	51"	61½"	21½"	57¾"	32½"	6"	3½"	1½"	15¼"	23"	10½"	12"	12"	14"	12"	3" NPT	1½" NPT	1½" NPT	
3000	29½"	34"	78"	59½"	69½"	28"	66¾"	41"	6"	3½"	1½"	15¼"	23"	10½"	12"	12"	14"	12"	3" NPT	1½" NPT	1½" NPT	
3500	29½"	34"	87"	63½"	76"	28½"	71"	44"	20"	3½"	2½"	15¼"	22½"	10½"	14"	14"	16"	14"	4" NPT	1½" NPT	2" NPT	
4000	29½"	34"	92"	68½"	81"	33½"	76"	49"	20"	3½"	2½"	15¼"	22½"	10½"	14"	14"	16"	14"	4" NPT	1½" NPT	2" NPT	
4500	29½"	34"	97"	73½"	86"	38½"	81"	54"	20"	3½"	2½"	15¼"	22½"	10½"	14"	14"	16"	14"	4" NPT	1½" NPT	2½" NPT	
5000	29½"	34"	102"	78½"	91"	43½"	86"	59"	20"	3½"	2½"	15¼"	22½"	10½"	14"	14"	16"	14"	4" NPT	1½" NPT	2½" NPT	

†For models 500 - 1200 appliance inlet/outlet connections are 2". For models 1500 - 5000 appliance inlet/outlet connections are 3".

PART 2 VENTING

⚠ DANGER

It is extremely important to follow these venting instructions carefully. Failure to do so can cause severe personal injury, death or substantial property damage.

⚠ DANGER

Foam Core Pipe, PVC, CPVC are not to be used in any part of the venting system.

2.1 GENERAL VENTING GUIDE

Figure 1

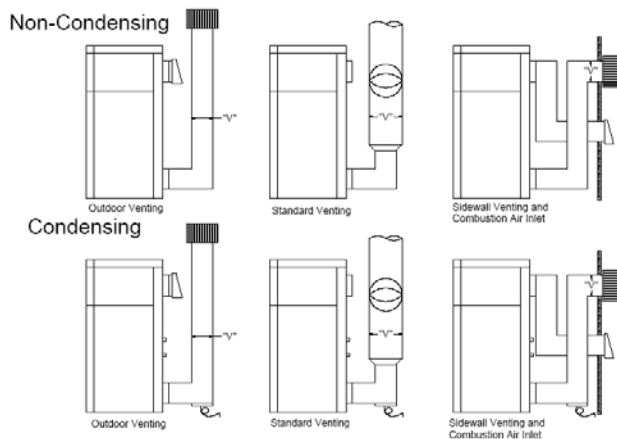

The DynaFlame is a category I, 85% efficient unit, supplied as a non-condensing appliance.

- When supplied with the Condenser Heat Recovery Module (CHRM). The DynaFlame is 95% efficient and is considered to be a category II appliance.
- Vent installations for connection to gas vents or chimneys must be in accordance with Part 7, "Venting of Equipment," of the latest edition of the National Fuel Gas Code, ANSI Z223.1, in Canada, the latest edition of CAN/CGA Standard B149 Installation Codes for Gas Burning Appliances and Equipment or applicable provisions of the local building codes.
- The distance of the vent terminal from adjacent buildings, windows that open and building openings MUST comply with the latest edition of the National Fuel Gas Code, ANSI Z223.1, in Canada, the latest edition of CAN/CGA Standard B149 Installation Code for Gas Burning Appliances and Equipment.
- Vent connection is made directly to the flue outlet opening on the back of the unit. The connection from the appliance vent to the stack must be made as direct as possible.
- Appliances for outdoor installation are intended to vent using a listed vent cap. For indoor installations venting must be in accordance with Part 7, Venting of Equipment, of the National Fuel Gas Code, ANSI Z223.1, or Section 7, Venting of Equipment and Air Supply for Appliances, of the CAN/CGA B149, Installation Codes, or applicable provisions of the local building codes.
- Vent connectors serving appliances vented by natural

draft shall not be connected into any portion of mechanical draft systems operating under positive pressure.

- Horizontal runs of vent pipe shall be securely supported (approximately every 4 feet) to prevent sagging and maintain a minimum upward slope of 1/4" per foot from the appliance to the vent terminal.
- The weight of the venting system must not rest on the unit. Adequate support of the venting system must be provided in compliance with local codes and other applicable codes.
- All connections should be secured and sealed per the vent manufacturers specifications. When a Positive vent system is disconnected for any reason, the flue must be reassembled and resealed according to the vent manufacturer's instructions.
- Do not use an existing chimney as a raceway if another appliance or fireplace is vented through the chimney.

2.1.1 CATEGORY I AND CATEGORY III VENTING

A Category I or III venting system for the flue products is required on all non-condensing models (DynaFlame without CHRM). A Category I venting system operate with a negative pressure in the vent. The Category III venting system operates with positive pressure generated by the internal combustion air fan.

- The Category I flues from multiple appliances can be combined into a common vent using recommendations from published venting tables.
- Controls of single or multiple Category I appliances may subject appliances to low fire operation for long periods depending on control strategies being used. Under this condition the venting does not reach the temperatures required for evaporation of flue gas condensation generated from initial start-up. To prevent nuisance condensation, avoid this operating condition or use corrosion resistant stainless steel venting.
- The Category III flues from multiple appliances can NOT be combined into a common vent.
- The Category III flue must be a dedicated stack.
- The Category III Flue appliance must have all vent joints and seams gas-tight. Unless a special venting system made from AL29-4C is used which has integral seals, all vent connector seams and joints must be sealed with pressure sensitive aluminium tape or silicone sealant as specified by the vent manufacturer. Aluminium tape must meet the provisions of SMACNA AFTS -100-73 Standard.
- The flue products in a category III vent system may be cooled below their dew point and form condensate in the flue. Corrosion resistant stainless steel must be used for the venting.
- When venting category III appliance thru unheated spaces insulation should be wrapped around single wall vent pipe to minimize the possibility of flue gas condensation inside the vent unless AL29-4C special venting is used. The authorities have jurisdiction must approve venting prior to insulating.
- The flue from a Category III vent system must have provisions to properly collect and dispose of any condensate that may occur in the venting system.

2.1.2 Venting Guidelines for Category I and/or III

Venting

- The installed length of the positive pressure flue from the appliance to the point of termination, outside of the building, must not exceed a maximum of 100 equivalent feet (30.5 m) in length. Depending on diameter and centreline radius subtract from 7 to 19 feet per 90° elbow using published data. Subtract half this value for each 45° elbow.
- The flue may terminate either vertically at the roof top or horizontally on a THRUWALL. See the information about the specific vent termination location for recommended location and clearances.

2.1.3 CATEGORY II AND CATEGORY IV VENTING

A Category II or IV venting system for the flue products is required on all condensing models (DynaFlame with CHRMs).

A Category II venting system operates with a negative pressure in the vent.

The Category IV venting system operates with positive pressure generated by the internal combustion air fan which operates the combustion process and also exhausts the flue products from the building.

- The Category II flues from multiple appliances can be combined into a common vent, this special venting system must be engineered by venting manufacturer and to be approved by local authority.
- The Category IV flues from multiple appliances can NOT be combined into a common vent.
- The Category IV flue must be a dedicated stack.
- The Category IV Flue appliance must have all vent joints and seams sealed gas-tight
- The flue products in the vent system will be cooled below their dew point and form condensate in the flue and must use AL29-4C material.
- The flue from a Category II and IV vent system must have a condensate drain with provisions to properly collect and dispose of any condensate that may occur.

2.1.4 Venting Guidelines for Category II and/or IV Venting

- The installed length of the Positive pressure flue from the appliance to the point of termination, outside of the building, **must not exceed a maximum of 100 equivalent feet (30.5M) in length.** Depending on diameter and centerline radius subtract from 7 to 19 feet per 90° elbow using published data. Subtract half this value for each 45° elbow.
- The flue may terminate either vertically at the roof top or horizontally on a THRUWALL. See the information about the specific vent termination location for recommended location and clearances.

2.1.5 APPROVED VENTING MATERIALS

Exhaust Vent for Use for DynaFlame Non-condensing Category I Installations

- 1 "B" type.
- 2 Stainless Steel Single Wall (required when operating appliance at low fire for long periods).
- 3 "C" Vent.
- 4 Equivalent or higher rated than above

Exhaust Vent for Use for DynaFlame Non-condensing Category III Installations

- 1 Corrosion resistant stainless steel single wall.

- 2 AL 294Cor equivalent, single or double wall.

Exhaust Vent for Use for DynaFlame Condensing Category II or IV Installations

- 1 AL294Cor equivalent, Single or Double Wall.
- 2 "BH" type.

Intake Air (Supply Air, or Fresh Air) Piping

- 1 PVC Non Foam Core Pipe.
- 2 CPVC (Chlorinated Polyvinyl Chloride).
- 3 ABS (Acrylonitrile-Butadiene-Styrene).
- 4 **Single wall**, galvanized
- 5 **Single wall**, Stainless Steel

Single wall vent pipes are to be insulated 5 feet from wall toward the interior of the building to minimize external sweating.

2.1.6 VENT TERMINATION CLEARANCES

- Do not terminate the vent in a window well, stairwell, alcove, courtyard or other recessed area. The vent cannot terminate below grade. The bottom of the vent terminal shall be located at least 12 inches (30cm) above grade and above normal snow levels. In all cases the appliance shall be installed in accordance with local codes.
- To avoid a blocked flue condition, keep the vent cap/terminal clear of snow, ice, leaves, debris, etc.
- Flue gases from this appliance may contain large amounts of water vapour that will form a white plume in winter. Plume could obstruct a window view.
- Flue gas condensate can freeze on exterior walls or on the vent cap. Frozen condensate on the vent cap can result in a blocked flue condition. Some discoloration to exterior building surfaces can be expected. Adjacent brick or masonry surfaces should be protected with a rust resistant sheet metal plate.

2.1.7 INLET CAP FOR ROOFTOP TERMINATION

The air inlet cap consists of two 90° elbows installed at the point of termination for the air inlet pipe. The first 90° elbow is installed on the rooftop at the highest vertical point of the air inlet pipe and turned horizontal; the second 90° elbow is screened and is installed on the horizontal outlet of the first elbow and turned down. A 90° elbow and a 90° street elbow may be used to make this assembly. If a straight piece of pipe is used between the two elbows, it should not exceed 6" (150mm) in length.

2.1.8 LOCATION OF A ROOFTOP AIR INLET AND VENT CAPS

- The point of termination for the combustion air inlet cap MUST be at least 3 feet (0.91M) below the point of flue gas termination (vent cap) if it is located within a 5 foot (1.5M) radius of the flue outlet. Use care to ensure that the 90° elbow assembly is properly installed on the air inlet pipe.
- The termination point of the combustion air inlet cap must be installed at least 3 feet (0.91M) above the rooftop and above normal snow levels.
- The vent cap assembly MUST be listed by nationally recognized agencies.
- The combustion air cap and vent cap MUST be located on the same roof top surface and in the same pressure zone

- Combustion air supplied from outdoors must be free of contaminants. To prevent recirculation of flue products in to the combustion air inlet, follow all instructions in this section.
- Incorrect installation and/or location of the air inlet cap can allow flue products to be drawn back into the appliance. This can result in incomplete combustion and potentially hazardous levels of carbon monoxide in the flue products. This will cause operational problems with the appliance and if left uncorrected, will lead to conditions that can cause personal injury or death.

2.1.9 AIR INLET DAMPER

In warmer climates, during cold weather, the use of ducted outdoor air may result in the formation of condensation on the interior panels of the combustion chamber. It may be possible for this condensation to accumulate and drip out of the appliance jacket. If this is not acceptable, it is advisable to install a motorized combustion air damper in the combustion air duct interlocked with the appliance's start circuit. In cold climates it is essential to provide a motorized air inlet damper to control the supply of combustion air and prevent nuisance condensation

2.1.10 MASONRY CHIMNEY INSULATIONS

Always follow local codes when venting this appliance into a masonry chimney. A standard masonry chimney must NOT be used to vent the products of combustion from the flue of a Condensing, positive or negative pressure appliance (Category II or IV). If a masonry chimney is to be used, the chimney MUST use a sealed, metallic, corrosion resistant liner system to vent flue products from this high efficiency appliance. Sealed, metallic, corrosion resistant liner systems (AL29-4C or equivalent, single wall or double-wall, or flexible or rigid metallic liners) must be rated for use with a high efficiency condensing, positive pressure vent system. Corrosion resistant chimney liner systems are typically made from a high grade of corrosion resistant stainless steel such as AL29-4C or equivalent. The corrosion resistant liner must be properly sized and fully sealed throughout the entire length. If the flue is contained within the masonry chimney both the top and the bottom of the masonry chimney must be capped and sealed to provide a dead air space around the sealed corrosion resistant metallic liner.

Consult with local code officials to determine code requirements or the advisability of using a masonry chimney with a sealed corrosion resistant liner system.

2.1.11 Vertical Venting Termination

- Follow Category II or IV vent termination and all General instructions.
- The vent terminal should be vertical and exhaust outside the building at least 2 feet (0.61M) above the highest point of the roof within a 10 foot (3.05M) radius of the termination.
- The vertical termination must be a minimum of 3 feet (0.91M) above the point of exit.
- A vertical termination less than 10 feet (3.05M) from a parapet wall must be a minimum of 2 feet (0.61M) higher than the parapet wall.

2.1.12 COMBINED COMBUSTION AIR INLET

The air inlet pipes from multiple appliances can be combined to a single common connection if the common air

inlet pipe has a cross sectional area equal to or larger than the total area of all air inlet pipes connected to the common air inlet pipe.

Equivalent pipe diameter = Sq Root $[(d_1)^2 + (d_2)^2 + (d_3)^2 + (d_4)^2 + \dots + (d_n)^2]$, d, pipe diameter

- ❖ Example: What is equivalent pipe diameter of three air inlet pipes, 8" (20.3 cm), 10" (25.4 cm) and 12" (30.5 cm)

Equivalent pipe diameter = Sq Root $[(8)^2 + (10)^2 + (12)^2] =$ Sq Root (308) = 17.5", Select 18" (82.8 cm) diameter pipe or larger.

The air inlet point for multiple boiler air inlets must be provided with an exterior opening which has a free area equal to or greater than the total area of all air inlet pipes connected to the common air inlet. This exterior opening for combustion air must connect directly to the outdoors. The total length of the combined air inlet pipe must not exceed a maximum of 100" (30.5M) equivalent feet. You must deduct the restriction in area provided by any screens, grills or louvers installed in the common air inlet point. Screens, grills or louvers installed in the common air inlet can reduce the free area of the opening from 25% to 75% based on the materials used. Calculate and compensate accordingly for the restriction.

2.1.13 DRAIN TEE

Figure 2 – Drain "T" and Neutralizer Cartridge Installation

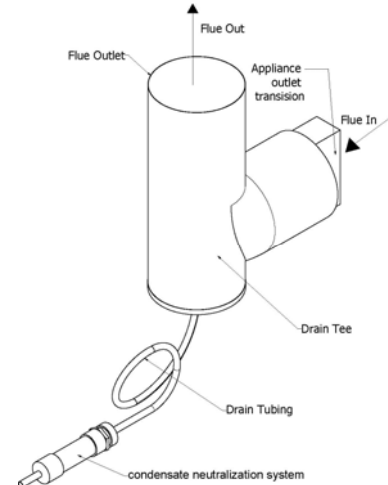

A drain tee **MUST** be installed in the Condensing vent pipe to collect and dispose of any condensate that may occur in the vent system. The drain tee should be installed at the point where the flue turns vertical for a roof top termination or as one of the first fittings in a horizontal flue that will terminate on a THRUWALL. Ensure that horizontal portions of the vent are properly sloped to allow condensate to be evacuated at the drain tee. Plastic drain tubing, sized per the vent manufacturer's instructions, shall be provided as a drain line from the tee. The drain tubing must have a trap provided by a 4" (10cm)-diameter circular trap loop in the drain tubing. Prime the trap loop by pouring a small quantity of water into the drain hose before assembly to the vent. Secure the trap loop in position with nylon ties. Use caution not to collapse or restrict the condensate drain line with the nylon wire ties. The condensate drain must be routed to the

condensate neutralization system or a suitable drain for disposal of condensate that may occur in the vent system.

Ensure that the drain from the condensate tee is not exposed to freezing temperature.

2.2 CONVENTIONAL VENTING (INDOOR) INSTALLATIONS

• NON – CONDENSING

- The DynaFlame non-condensing is a category I appliance and is approved for venting into a common standard chimney. If drafts are excessive (above negative 0.15 Inches W.C.), install a single acting barometric damper directly past the appliance's flue outlet. This damper will control excessive draft & minimize standby losses.
- Multiple appliances may be vented into a conventional chimney. The chimney must be lined. And a single acting barometric damper must be provided for each appliance. Vent diameters are to be increased according to following table 4.

Table 4: Vent Size for Conventional venting

Model No.	Sidewall, Condensing or Outdoor Vent Size, Inch	Conventional Vent size, Inch
500	6	8
750	8	10
1100	8	10
1200	8	10
1500	10	12
1750	10	12
2000	12	14
2500	12	14
3000	12	14
3500	14	16
4000	14	16
4500	14	16
5000	14	16

- The chimney must be protected from down drafts, rain and debris by using a listed chimney cap.
- If the appliance is located in a room maintained at low temperature and is being run for extended periods of time at low fire it is likely that condensation will be formed in the vent. Consideration must be given to heating the room or providing a special venting system similar to that used for condensing appliance application

• CONDENSING

- The DynaFlame condensing version is a category II appliance and is approved for venting into a common Chimney. If drafts are excessive (above negative 0.15 Inches W.C.), we recommend a single acting barometric damper.
- A qualified professional using a proven vent-sizing program with input of accurate operating parameters must properly do sizing of the venting system. In applications where flue gas temperatures are lower than can support a Category II with conventional negative draft, it will be determined at the venting design stage that a positive pressure will be developed in the vent. It will then be necessary to either provide

separate vents as for Category IV, pressurize the room or to provide an extractor at the chimney outlet interlocked with the appliance operating circuit in order to maintain a negative draft in the chimney and allow common venting.

- Approval of the installation will be at the discretion of authorities having jurisdiction.

• IN GENERAL

- The operation of exhaust fans, compressors, air handling units etc. can rob air from the room, creating a negative pressure condition leading to reversal of the natural draft action of the venting system. Under these circumstances an engineered air supply is necessary.
- If the appliance is to be installed near a corrosive or potentially corrosive air supply, the appliance must be isolated from it and outside air should be supplied as per code.
- Potentially corrosive atmospheres will result from exposure to permanent wave solution, chlorinated waxes and cleaners, chlorine, water softening chemicals, carbon tetrachloride, halogen based refrigerants, Freon cleaning solvents, hydrochloric acid, cements and glues, masonry washing materials, antistatic fabric softeners, dry cleaning solvents, degreasing liquids, printing inks, paint removers, etc.
- The equipment room MUST be provided with properly sized openings to assure adequate combustion air and proper ventilation when the unit is installed with a proper venting system.

2.2.1 Air Required For Combustion and Ventilation

If air is taken directly from outside the building with no duct, provide two permanent openings:

- a) Net free area for combustion air opening shall be in accordance with all applicable codes. In the absence of such codes provide combustion air opening with a minimum free area of one square inch per 7000 Btuh input (5.5 cm per kW) up to 1,000,000 Btuh and one square inch per 14,000 Btuh in excess of 1,000,000 Btuh. This opening must be ducted no .higher than 18" nor less than 6" above the floor. Provide a ventilation air opening located as high as practical in the room sized no less than 10% of the air supply opening.
- b) Provision for combustion and ventilation must be in accordance with :
 - Applicable sections of The National Fuel Gas ode ANSI Z223.1
 - Applicable sections of CAN/CGA B149 installation Codes
 - Applicable provisions of the local building codes.

NOTE

Outside air openings shall directly communicate with the outdoors.

CAUTION

Under no circumstances should the mechanical room ever be under a negative pressure. Particular care should be taken where exhaust fan, attic fans, clothes dryers, compressors, air handling units, etc., may take away air from the unit.

2.2.2 EXHAUST FANS

Any fan or equipment which exhausts air from the equipment room may deplete the combustion air supply

and/or cause a downdraft in the venting system through a barometric damper if installed. Spillage of flue products from the venting system into an occupied living space can cause a very hazardous condition that must be immediately corrected.

2.3 OUTDOOR VENTING

The DynaFlame windproof cabinet protects the unit from weather, when fitted with the factory supplied air intake and UL approved vent cap (93-0298), it will be self-venting and suitable for outdoor installation.

1. Outdoor models must be installed outdoors and must use the Air Intake and Vent Cap supplied by Camus Hydronics.
2. Periodically check to ensure that air intake and vent cap are not obstructed.
3. Locate appliance at least 3 feet away from any overhang.
4. Locate appliance at least ten feet from building air intake.
5. Avoid installation in areas where runoff from adjacent building can spill onto appliance.

For outdoor installations, always consider the use of a shelter such as a garden shed in lieu of direct exposure of the appliance to the elements. The additional protection afforded by the shelter will help to minimize nuisance problems with electrical connections and will allow easier servicing of the appliance under severe weather conditions.

2.4 THRUWALL VENTING

When fitted with the factory supplied vent terminal, the DynaFlame can vent up to 100 equivalent feet. Elbows can range from 7 to 19 feet in equivalent length depending on centreline radius. Vent sizes are 6" for Model 500, 8" for Models 750, 1100 & 1200, 10" for Models 1500 & 1750, 12" for Models 2000, 2500 & 3000, and 14" for Models 3500, 4000, 4500 & 5000

Appliances may be installed with either a horizontal sidewall vent or vertical roof top vent. Terminals differ with each application. Horizontal lengths over 5 feet must be installed using corrosion resistant stainless steel. Use single wall vent and seal all joints or use pressure rated double wall vent.

When using single wall vent, all vent connector seams and joints must be sealed with pressure sensitive aluminium tape or silicone sealant as specified by the vent manufacturer. Aluminium tape must meet the provisions of SMACNA AFTS-100-73 Standard.

When venting through unheated spaces, use venting material which will minimize flue gas condensation inside the vent. Provisions must be made for collecting and disposing of any condensation which may occur. The authorities having jurisdiction must approve venting.

Periodically check to ensure that the vent terminal is unobstructed.

This venting system uses the appliance's internal combustion air fan to force the flue products out

horizontally. Vent cap and venting must be listed type Category IV vent materials.

The DynaFlame fan generates a positive pressure in the flue. Combustion air is drawn from the equipment room. The THRUWALL termination caps are available from the factory as a kit.

Refer to local codes for proper installation and location of vent terminals.

2.4.1 THRUWALL Vent Cap (14-0090) THRUWALL Intake Air Cap (14-0101)

- The THRUWALL vent cap kit includes the wall penetration assembly and the discharge screen assembly.
- The opening through the wall for installation of the THRUWALL vent cap must provide an air space clearance of 1 inch (2.5cm) around the flue pipe. The diameter of the opening for installation of the THRUWALL vent cap will be 2 inches (5cm) larger than the nominal diameter of the installed vent pipe to the THRUWALL vent cap. The diameter of the opening for the air inlet cap will be the same as the nominal size of the pipe.
- Install the proper vent pipe to the vent cap (provided by Camus Hydronics).
- Follow all requirements in the General Venting sections for venting flue products to the outdoors.

Table 5 – Vent and Air Inlet Cap Size

Model No.	Vent and Air Inlet cap size
500	6"
750	8"
1100	8"
1200	8"
1500	10"
1750	10"
2000	12"
2500	12"
3000	12"
3500	14"
4000	14"
4500	14"
5000	14"

2.4.2 Location of A THRUWALL Vent Termination

- The vent cap shall terminate at least 3 feet (1M) above any forced air inlet within 10 feet (3M) horizontally.
- The vent cap MUST NOT terminate below a forced air intake at any distance.
- Do not terminate the vent in a window well, stairwell, alcove, courtyard or other recessed area. The vent cannot terminate below grade.
- The vent shall not terminate less than 7 feet above a public walkway due to the normal formation of water vapour in the combustion process.
- The vent system shall terminate at least 3 foot (1M) above grade, above normal snow levels and at least 7 feet (2.15M) above grade when located adjacent to public walkways.
- The vent terminal shall not be installed closer than 3 feet (1M) from an inside corner of an L-shaped

structure.

- The vent cap should have a minimum clearance of 4 feet (1.25M) horizontally from and in no case above or below, unless a 4-foot (1.25 m) horizontal distance is maintained from electric meters, gas meters, regulators and relief equipment. In all cases local codes take precedence.
- Flue gas condensate can freeze on exterior walls or on the vent cap. Frozen condensate on the vent cap can result in a blocked flue condition. Some discoloration to exterior building surfaces can be expected. Adjacent brick or masonry surfaces should be protected with a rust resistant sheet metal plate.
- The THRUWALL vent cap MUST be purchased as a kit from the factory to ensure proper operation. Locally purchased or fabricated THRUWALL vent caps should not be used.

2.4.3 LOCATION OF A “THRUWALL” AIR INLET CAP

- The termination point of the THRUWALL air inlet must be installed a minimum of 3 feet above ground level and above normal levels of snow accumulation.
- The point of termination for the THRUWALL combustion air inlet cap MUST be located a minimum of 3 feet (1M) horizontally and 12 inches (0.30M) below the point of flue gas termination (vent cap) if it is located within a 10 foot (3M) radius of the flue outlet.

2.4.4 AIR INLET DAMPER

- In warmer climates, during cold weather, the use of ducted outdoor air may result in the formation of condensation on the interior panels of the combustion chamber. It may be possible for this condensation to accumulate and drip out of the appliance jacket. If this is not acceptable, it is advisable to install a motorized combustion air damper in the combustion air duct interlocked with the appliance’s start circuit. In cold climates it is essential to provide a motorized air inlet damper to control the supply of combustion air and prevent nuisance condensation

2.4.5 LENGTH OF AIR INLET PIPE

The maximum total length of the THRUWALL or vertical roof top combustion air inlet pipe as installed from the appliance to the air inlet cap must not exceed (100 ft) equivalent feet (30.5m) in length. Subtract 7 (2.13 m) to 19 feet (5.8 m) of equivalent length depending on centreline radius for each 90° elbow installed in the air inlet pipe system. Pressure drop in 45° elbow will be half as much.

Do not exceed limits for the combustion air inlet piping lengths.

PART 3 GAS CONNECTION

Verify that the appliance is supplied with the type gas specified on the rating plate. Consult factory for installations at high altitude.

3.1 GAS CONNECTION

- Safe operation of unit requires properly sized gas supply piping. See gas line sizing data.
- Gas pipe size may be larger than appliance connection.
- Installation of a union at the appliance gas line connection is required for ease of service and removal

of the gas train.

- Install a manual main gas shutoff valve, outside of the appliance gas connection as require by local codes.
- A trap (drip leg) MUST be provided in the inlet gas connection to the appliance.
- Optional gas controls may require routing of bleeds and vents to the atmosphere, outside the building when required by local codes.

Table 6 – RECOMMENDED GAS PIPE SIZE
Single Appliance Installation
(For distance from natural gas meter or propane second stage regulator)

Input Btu/Hr	0-100 FT	
	NAT.	L.P.
500,000	1 ½"	1 ¼"
750,000	2"	1 ½"
1,100,000	2"	1 ½"
1,200,000	2"	1 ½"
1,500,000	2 ½"	2"
1,750,000	2 ½"	2"
2,000,000	2 ½"	2"
2,500,000	3"	2 ½"
3,000,000	3"	2 ½"
3,500,000	3"	2 ½"
4,000,000	3 ½"	3"
4,500,000	3 ½"	3"
5,000,000	4"	3 ½"
Input Btu/Hr	101-200 FT	
	NAT.	L.P.
500,000	2"	1 ½"
750,000	2"	1 ½"
1,100,000	2"	1 ½"
1,200,000	2 ½"	2"
1,500,000	2 ½"	2"
1,750,000	3"	2 ½"
2,000,000	3"	2 ½"
2,500,000	3"	2 ½"
3,000,000	3"	2 ½"
3,500,000	3 ½"	3"
4,000,000	4"	3 ½"
4,500,000	4"	3 ½"
5,000,000	4"	3 ½"
Input Btu/Hr	201-300 FT	
	NAT.	L.P.
500,000	2"	1 ½"
750,000	2 ½"	2"
1,100,000	2 ½"	2"
1,200,000	2 ½"	2"
1,500,000	3"	2 ½"
1,750,000	3"	2 ½"
2,000,000	3"	2 ½"
2,500,000	3 1/2"	3"
3,000,000	3 1/2"	3"
3,500,000	4"	3 ½"
4,000,000	4"	3 ½"
4,500,000	4"	3 ½"
5,000,000	5"	4"

3.2 GAS PIPING

All gas connections must be made with pipe joint compound resistant to the action of liquefied petroleum and natural gas. All piping must comply with local codes and ordinances.

3.3 INSTALL PIPING

- The gas line should sufficient to handle the total installed capacity. Verify pipe size with your gas supplier.
- Use new, properly threaded black iron pipe free from burrs. Avoid flexible gas connections. Internal diameter of flexible gas lines may not provide appliance with proper volume of gas.
- Install a manual main gas shutoff valve at the appliance gas inlet, outside of the appliance and before the gas valve. Install a joint union at the appliance gas line connection for ease of service and removal of the gas train.
- Run pipe to the Appliance gas inlet.
- Install a sediment trap in the supply line to the Appliance gas inlet.
- Apply a moderate amount of good quality pipe compound.
- For LP gas, consult your LP gas supplier for expert installation.

The appliance and its individual gas shut-off valve must be disconnected from the supply piping when pressure testing the gas supply piping at pressures above ½ PSI

Table 7 – Gas pressures at inlet to appliance

	PROPANE	NATURAL GAS
Minimum (inches W.C.)	11	3
Maximum (inches W.C.)	11	14

The gas supply line must be of adequate size to prevent undue pressure drop and must never be smaller than the size of the connection on the appliance. Sizing based on Table 6 is recommended.

Before operating the appliance, the complete gas train and all connections must be tested using soap solution.

Verify that the appliance is supplied with the type gas specified on the rating plate. Heating values of local natural gas are to be between 950 and 1010 Btu/ft³. Consult factory if heating values are outside this range or if a gas with a mixture of constituents is being used.

3.4 DIFFERENTIAL AIR PRESSURE

- The Dynaflame operates on the principle of differential pressures. Operation of the fan generates a signal which is matched on the gas side by the 1 to 1 air/gas ratio control valve.
- The differential air pressure measurement is made between the high and low pressure taps across the fan discharge and the flue vent. All differential air pressures are noted at full firing rate. There are two pressure taps at the fan discharge and care must be taken to tee into the correct line. The correct line may be identified by tracing it back to the ratio control valve where the identification of the tapping is stamped into the die cast actuator.

- The differential gas pressure measurement is made between the high and low pressure taps across the in-line metering gas orifice. Check this value to confirm that it matches the differential air pressure while the appliance is firing.
- The controls on this appliance may fire the burner from 35% up to 100% for non-condensing and from 20% up to 100 % for condensing of rated input.
- Differential manifold gas pressure will be reduced as burner input is reduced.
- All reference gas pressure measurements must be made at 100% of rated burner input.
- The differential gas manifold pressure is pre-set at the factory through the ratio gas valve. Adjustment of manifold pressure is not normally required for proper operation. In the field it may be necessary to adjust the low fire adjustment screw located on the ratio control valve actuator in order to achieve acceptable light off under soft start field conditions.

Table 8

NOMINAL DIFFERENTIAL AIR PRESSURE SETTINGS AT FULL FIRE (inches W.C.)	
Model No.	Natural Gas & L. P. Gas
500	1.3
750	1.8
1100	2.6
1200	3.4
1500	2.7
1750	3.0
2000	3.7
2500	4.0
3000	4.8
3500	3.7
4000	5.0
4500	7.6
5000	9.5

3.5 GAS MANIFOLD DIFFERENTIAL PRESSURE ADJUSTMENT

Tampering with gas valve adjustments after startup and commissioning will void the warranty on the gas valve assembly and the burner.

The appliance's manifold gas pressure **IS NOT** field adjustable after startup and commissioning. The gas valve pressure ratios have been factory set with an internal bias adjustment to ensure a 1:1 air/gas ratio on operation. Tampering with this adjustment will void the warranty on the gas valve assembly and the burner. An appliance supplied with a properly sized gas line, properly sized meter and a minimum gas supply pressure (See table 7 for minimum allowable inlet gas supply pressure) while firing at full rate will ensure full burner input. The manifold pressure supplied to the burner is a differential pressure. This pressure is the result of the difference in two gas pressure measurements. A differential manifold gas pressure measurement should not be made until you have measured the gas supply pressure. Gas supply pressure must be at least at minimum allowed with all appliances on the gas line firing at full rate before a manifold pressure measurement is made. Use the following procedure to check gas supply pressure with a manometer connected to the inlet pressure tap on the gas line connection at the rear of the appliance.

3.6 CHECKING GAS SUPPLY PRESSURE

- Turn the main power switch to “OFF” position.
- Shut off gas supply at the manual gas cock in the gas piping to the appliance. If fuel supply is LP gas, shut off gas supply at the tank.
- Remove the 1/8" hex plug from the gas pressure test port located on the inlet gas supply connection at the rear of the appliance. Install a fitting in the inlet pressure tapping suitable to connect to a manometer or magnahelic gauge. Range of scale should be 0 to 14 inch W.C. or greater to check inlet pressure
- Turn on gas supply at the field installed manual gas cock; turn on LP gas at tank if required.
- Turn the power switch to “ON” position.
- Adjust the thermostat set point to call for heat.
- Observe the gas supply pressure as the burner fires at 100% of rated input.
- Ensure inlet pressure is within specified range. Minimum and maximum gas supply pressures are specified in Gas Supply section of this manual.
- If gas pressure is out of range, contact the gas utility, gas supplier, qualified installer or service agency to determine necessary steps to provide proper gas pressure to the control.
- If gas supply pressure is within normal range, proceed to remove gas manometer and replace pressure tap fittings in the gas piping to the appliance.
- Turn on gas supply at the manual valve; turn on LP gas at tank if required.
- Turn the power switch to “ON” position.
- Adjust the thermostat temperature set point to the desired water temperature so the appliance will call for heat.
- Check appliance performance by cycling the system while you observe burner response. The burner should ignite promptly. Flame pattern should be stable, see “Maintenance-Normal Flame Pattern.” Turn system off and allow burner to cool, then cycle burner again to ensure proper ignition and flame characteristics.

IMPORTANT

Upon completion of any testing on the gas system, leak test all gas connections with a soap solution while the main burner is firing. Immediately repair any leak found in the gas train or related components. DO NOT operate an appliance with a leak in the gas train, valves or related gas piping.

3.7 CHECKING DIFFERENTIAL AIR AND GAS PRESSURES

Figure 3 – Differential Air Pressure Manometer Connection

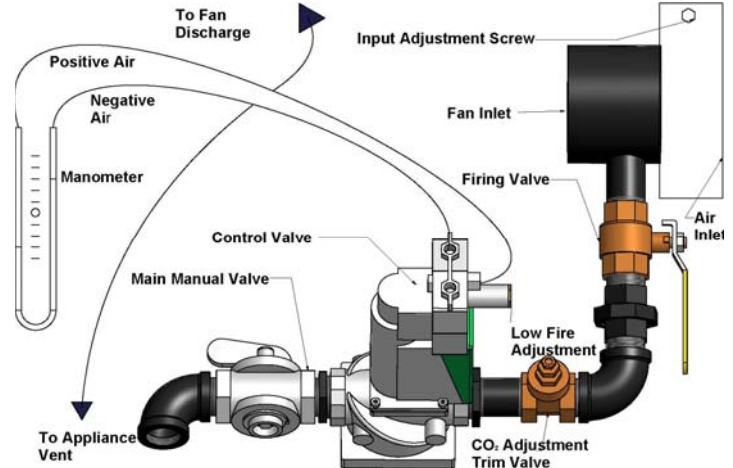

- The 1 to 1 air/gas ratio control actuator has embossed markings identifying + air – air, + gas & - gas connections. Using a test hose assembly fitted with tees, connections can be made from the manometer to the appropriate ports on the actuator.
- Using tees connect a hose from the positive air and the negative air to each of the two sides of a manometer. This will allow the two pressure points to be measured while at the same time the actuator still receives the proper operating signal.
- If a second manometer is available it can be connected to the appropriate gas ports. Typically the gas signal will closely follow the air signal on all models. If the incoming gas pressure reduces significantly as the Variable Frequency Drive (VFD) accelerates to 60 Hz the gas signal may lag behind the air signal by up to 15%. This will occur once the actuator has driven downwards as far as it can go. The amount that the actuator has opened is registered by an indicator arm which is visible through the view window.
- As the appliance comes on and fires, record the maximum inches of water column which is achieved at 60 Hz on the VFD using start-up report form (93-0130). To adjust this differential pressure, use the adjusting screw on the air shutter to the fan. Readings are to correspond to the values in table 2a. In all cases the final adjustment is to be made using a combustion analyzer. Depending on field conditions differential pressures will have to be adjusted accordingly. Typically with long lateral runs the differential signal as read will be reduced from the value shown in the table. The opposite will occur with tall stacks where drafts exceed negative 0.15"W.C.
- If the appliance will not light off and the blue 'main flame' light is coming on but not staying on then it will be necessary to adjust the low fire as explained in the detailed start-up procedure.

3.8 GAS TRAIN AND CONTROLS

Figure 4 – Typical Gas Train

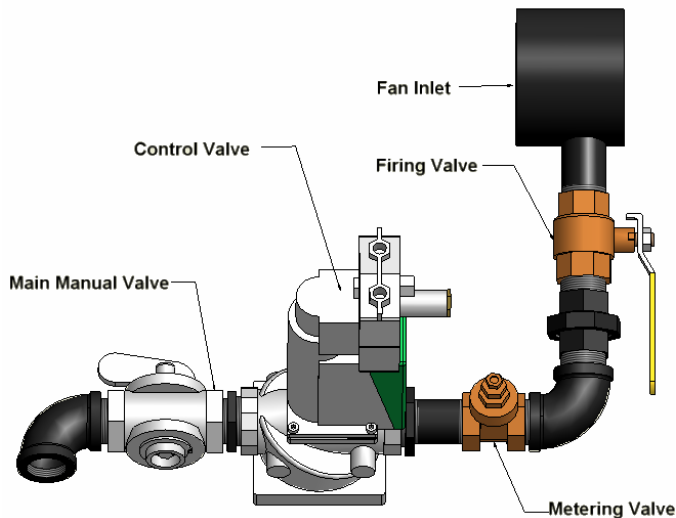

3.9 RATIO GAS VALVE

Figure 5 – 1:1 Air/Gas Ratio Control Valve

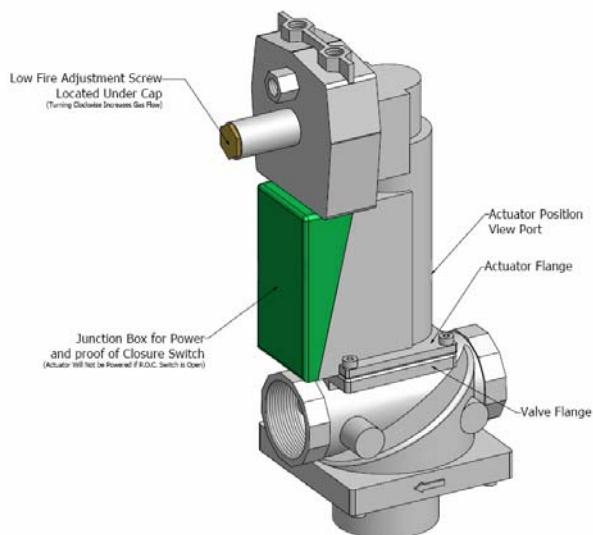

The main gas valve supplying gas to the burner on this appliance utilizes a pressure regulating electro hydraulic actuator providing a slow opening, fast closing safety shut off and air/gas ratio control for the gas combustion process. This gas valve controls the pressure difference across the restriction in the gas supply line as a function of the pressure difference across the combustion air supply to the burner. The actuator maintains a constant air to gas ratio as the volume of air changes based on the operation of the combustion air fan. The valve is a 1:1 differential pressure air/gas ratio controller. The valve generates the same pressure difference on the gas side as it senses on the air side. The valve performs the functions of pressure regulator, safety shutoff, and air/gas ratio control. Slow opening and safety shutoff is accomplished by operation of an electro hydraulic cylinder. Full closing of the valve seat occurs in less than 0.8 seconds when the valve is de-energized. A visual stroke position indicator is provided on the valve assembly to indicate the position of the valve seat. Operation of the gas valve in combination with the

combustion air fan allows the burner input rate to vary from 20% to 100% based on temperature demand. The inlet gas supply pressure must be maintained within the specified minimum and maximum pressures. A reduction of up to 30% is permitted in the inlet gas pressure between light off and full fire conditions.

The manifold differential pressure is preset at the factory and adjustment is not usually required if gas supply pressure is maintained within the specified range. If the manifold differential pressure is to be measured, follow the "Gas Manifold Pressure Measurement Procedure" for proper measurement.

There are no serviceable parts on the ratio gas valve actuator

3.10 VENTING OF GAS VALVES AND PRESSURE SWITCHES

The optional gas pressure switches may be provided with threaded termination points to be vented to the atmosphere, outside the building. The gas pressure regulation function is provided by the ratio gas valve which does not require installation of a vent line. The optional gas pressure switches are installed in the upper chamber of the appliance. Threaded vent line connections from components requiring an external vent line are provided on the component. These vent line connection points may be accessed by removing the top of the appliance. Local codes may require the routing of these bleeds and vents to the atmosphere, outside the building. Proper routing of vent lines to the atmosphere from the factory supplied termination points is the responsibility of the installing contractor.

3.10 BURNER

Figure 6 – Burner

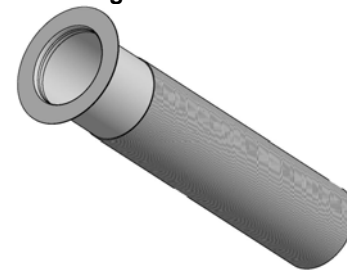

This appliance uses a single cylindrical burner installed vertically into the cavity located in the center of the primary heat exchanger. There is a unique burner for each one of the thirteen models.

Burners may NOT be interchanged between different Btu/hr input models. The burner consists of a round mounting flange welded to a mixing tube. The top side of the mixing tube provides the transition which mounts the discharge from the combustion air fan into the burner. The bottom side of the mixing tube is attached to a stainless steel perforated sleeve. This stainless steel sleeve is covered with a loose fitting, knitted alloy material that forms the burner port surface. The knitted burner port material is called metal fiber which is a unique alloy of iron, chrome, aluminum and several rare earth metals. This alloy is designed to operate stress free as a burner port surface. The burner port surface can sustain operation from a blue flame down to infrared conditions as the burner input

varies. In order to maximize the operating life of the burner, the normal operating mode for the Dynaflame is a blue flame. Infrared operation will occur only if air to gas adjustments is incorrect. If infrared operation is noted the cause must be corrected.

The burner mounting flange provides a flame view port and the mounting point for the hot surface igniter and the flame sensor. The hot surface igniter and flame sensor are removable from the burner mounting flange without removing the burner assembly from the heat exchanger.

Never use an open flame (match, lighter, etc.) to check gas connections.

PART 4 WATER CONNECTION

- Check all applicable local heating, plumbing and building safety codes before proceeding.
- If the appliance is installed above radiation level it must be provided with a low water cut-off device at the time of appliance installation (available from factory). Some local codes require the installation of a low water cut-off on all systems.
- A pressure relief valve is supplied with each DynaFlame. The relief valve must be mounted in a vertical position and piped to the floor in a manner acceptable to the enforcing authority.
- Be sure to provide unions and gate valves at inlet and outlet to the appliance so that it can be easily isolated for service. The provision of a flow setter valve at the appliance outlet will facilitate setting of the proper flow at the desired temperature rise at high fire. It is particularly important to confirm proper temperature rise for domestic hot water applications. Improper flows can lead to premature tube failure from erosion or scaling and will not be covered by warranty.
- This appliance is a low mass design which provides for instant heat transfer. Special attention to water flow rates will ensure that temperature rise is not excessive. See table 10.
- To eliminate trapped air, install venting devices at high points in the system as well as in the piping on the suction of the pump and in the piping on the discharge of the appliance.
- Use suitable pipe hangers or floor stands to support the weight of all water and gas piping.
- Always pump toward the heat exchanger inlet. Never pump away from the exchanger since this will result in a low-pressure zone, which will allow localized boiling and result in heat exchanger damage.
- Do not allow the appliance to run with inlet water temperature below 110°F (44°C) into the primary heat exchanger.
- DynaFlame must be installed so that the gas ignition system components are protected from water (dripping, spraying, rain, etc.) during appliance operation and service (circulator replacement, control replacement, etc.)

Figure – 7 Typical Space Heating System

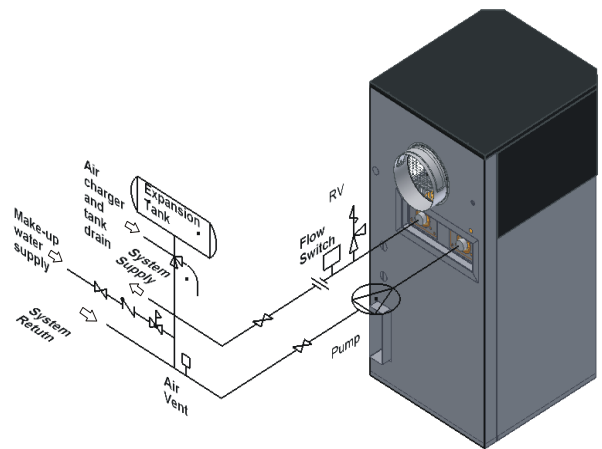

4.1 FREEZE PROTECTION

- Appliance installations are not recommended outdoors or in areas where danger of freezing exists unless precautions are taken. Maintaining a mixture of 50% water and 50% propylene glycol is the preferred method of freeze protection in hydronic systems. This mixture will protect the appliance to approximately -35°F (-37°C). To maintain the same temperature rise across the appliance increase the GPM flow by 15% and the head loss by 20%.
- For Outdoor installations a snow screen should be installed to prevent snow and ice accumulation around the appliance. Regular inspections should be made to ensure that air intake and vent are free of snow and ice. Always consider the use of a shelter such as a garden shed in lieu of direct exposure of the appliance to the elements. The additional protection afforded by the shelter will help to minimize nuisance problems with electrical connections and will allow easier servicing of the appliance under severe weather conditions.

4.2 WARNING REGARDING CHILLED WATER SYSTEMS

When an appliance is connected to an air conditioning system where the same water is used for heating and cooling, the chiller must be piped in parallel with the boiler. Appropriate flow control valves; manual or motorized must be provided to prevent the chilled water from entering the appliance.

Figure – 8 Chilled Water System

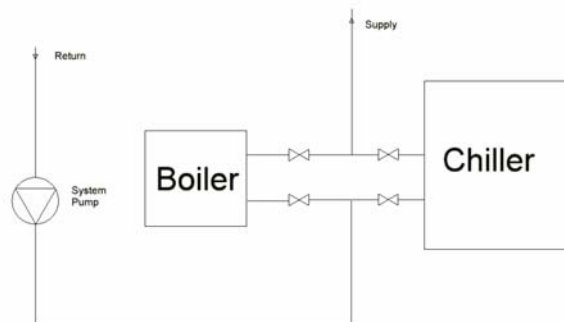

4.3 INLET AND OUTLET CONNECTIONS

- All water connections meet American National Standard Pipe Threads (NPT).
- For ease of service, install unions on inlet and outlet of the appliance. The connection to the appliance marked "Inlet" on the header should be used for return from the system. The connection on the header marked "Outlet" is to be connected to the supply side of the system.

4.4 MINIMUM PIPE SIZE REQUIREMENTS

Minimum water pipe connections are as follow for DynaFlame for single unit installations. The equivalent number of straight feet of pipe for each valve and fitting in the connecting piping must be considered to properly arrive at the total equivalent feet of straight pipe in the field installed piping to the appliance. See the piping requirements in Part 11 - Installation section of this manual. Consult factory if longer piping distances are required for a specific application.

Table 9 – Minimal System Pipe Size

Input, Btu/Hr	Water Size, NPT
500,000	2
750,000	2
1,100,000	2
1,200,000	2
1,500,000	2½"
1,750,000	2½"
2,000,000	3"
2,500,000	3"
3,000,000	3"
3,500,000	4"
4,000,000	4"
4,500,000	4"
5,000,000	4"

Note: Models 500 through 1200 have 2" threaded inlet and outlet connections. Models 1500 through 5000 have 3" threaded inlet and outlet connections. Provision must be made to mate the pipe size with the appliance inlet and outlet connections.

4.5 PRIMARY HEAT EXCHANGER

This appliance uses copper finned tubing to maximize the heat transfer process. The primary heat exchanger is comprised of vertical tubes rolled directly into two circular bronze headers. This heat exchanger is design to withstand 160 PSIG working pressure. A series of "V" shaped baffles are installed between the individual tubes to control the movement of the flue products over the finned tubes to maximize efficiencies.

A factory recommended circulating pump ensures proper water flow during burner operation and creates enough water turbulence inside the copper tubes and header that prevents the formation of sediments. Temperature rise and erosion prevention in the primary heat exchanger are controlled by the selection of a properly sized circulating pump. To ensure proper operation and ensure longevity of this heat exchanger minimum inlet water temperatures of 110 °F (44 °C) MUST BE maintained.

When return water temperatures are below approximately

110°F (44 °C), the flue products passing through the copper finned tubes will be cooled below their dew point resulting in the formation of corrosive condensation on the copper which shorten its life. Under these conditions condensation will collect in the base of the inner combustion chamber. Follow the piping recommendations given for low water temperature systems if water temperatures are expected to be below 110°F (44 °C). During initial operation of the appliance in a cold system some condensation will be generated but it will be quickly evaporated once the system return temperature reaches 110°F (44 °C).

IMPORTANT

Operating this appliance at return water temperatures below 110 °F (43.3 °C) (except initial heat up) may cause primary heat exchanger to fail and may eventually cause hazardous conditions that may result in personal injury or non-warrantable damage to the appliance.

4.6 LOW WATER TEMPERATURE SYSTEMS (non -condensing)

In applications where the heating system requires supply water temperatures below 110°F, a bypass line must be installed upstream of the appliance pump so that outlet water can be re-circulated to raise the inlet temp to a minimum of 110°F. Balancing valves, preferably circuit setter or globe valves are used to adjust flow. (See figure 9)

Figure – 9 Typical Low Water Temperature System

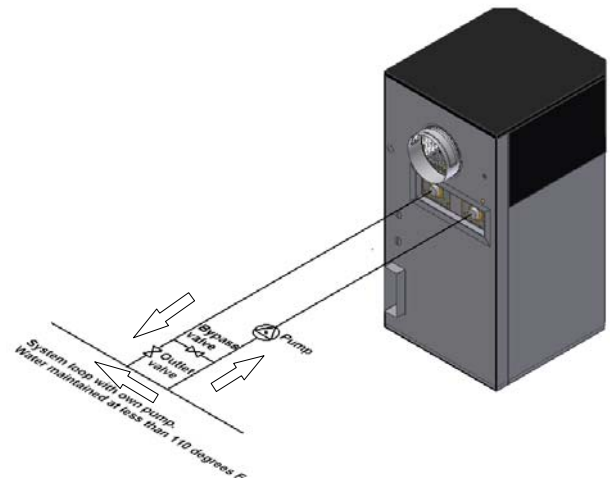

Adjustment Procedure.

- Fully open bypass and outlet valves.
- With appliance running, read appliance inlet temperature after 15 minutes.
- If inlet temperature is less than 110°F slowly close outlet valve until the inlet temperature climbs to 110°F
- If inlet temperature is greater than 110°F but not greater than 140°F no further adjustment is required.
- Check inlet temperature after 5 minutes and make final adjustments.
- Remove handle of balancing valve to prevent tempering.

Note: For applications where large volumes of water are heated from ground water temperatures to process temperatures, it will be necessary to provide a modulating three way valve in lieu of a fixed bypass line.

4.7 INSTANTANEOUS WATER HEATER (non-condensing)

An instantaneous water heater is designed to deliver hot water without the use of a storage tank. It is suitable for applications with variable load such as restaurants, condominiums, apartments and motels and typically used in conjunction with tempering valves to achieve temperature control. (See figure 10)

Figure – 10 Typical Instantaneous Water Heating System

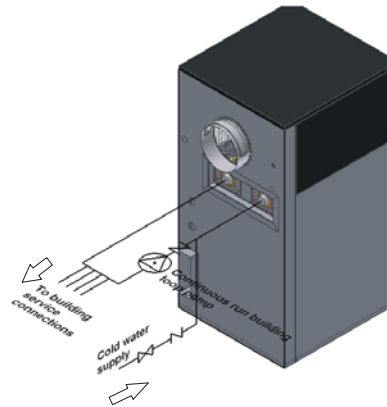

Table 10 – Flow and Pressure Drop at a Given Temperature Rise

Model	Heat Exchanger Water Content (USG)	30 °F (19.4 °C) Temp Rise		35 °F (19.4 °C) Temp Rise	
		USGPM (min. flow)	ΔP Ft.	USGPM. (min. flow)	ΔP Ft.
500	2.5	28.0	0.7	24.0	0.5
DF750	2.9	42.0	1.4	36.0	1.0
DF1100	3.5	61.6	2.7	52.8	2.1
DF1200	3.5	68.0	2.9	58.3	2.2
DF1500	6.3	83.9	4.5	71.9	4.0
DF1750	6.6	90.0	6.7	83.9	5.5
DF2000	7.0	111.9	4.1	95.9	3.1
DF2500	7.5	139.9	6.1	119.9	4.6
DF3000	8.0	167.9	8.4	143.9	7.0
DF3500	8.4	198.1	12.7	169.8	9.5
DF4000	8.9	226.9	17.0	194.5	12.7
DF4500	9.3	254.7	21.9	218.3	16.4
DF5000	9.7	282.9	27.6	242.5	20.7

4.8 CONDENSER HEAT RECOVERY MODULE (CHRM)

The DynaFlame ALL Stainless Steel CHRM is mounted in a stainless steel inner jacket chamber at the right side of the appliance facing the appliance. The CHRM is constructed from all stainless steel headers and special multiple horizontal stainless tubes. This CHRM is designed to maximize heat transfer efficiency by fully condensing flue products and is suitable to resist the low PH of condensate.

The CHRM must be supplied with adequate water flow at all times during operation. Do not operate the appliance with the CHRM piped out or isolated.

The CHRM is mounted in the discharge of the flue products from the primary heat exchanger. This allows additional

heat to be absorbed from the flue products exhausted from the combustion process. If isolation valves are provided on the CHRM, the provision of a relief valve at the outlet of the CHRM is recommended. This valve is to be sized at minimum for 10% of the input of the appliance and is to be piped to drain.

When cold water supply with temperatures less than 110 °F (44 °C) passes through the CHRM it will cool the flue products below dew points resulting in the formation of condensation. Furthermore, the volumetric flow rate of the flue gases will be reduced.

The appliance CHRM loop may be used in condensing mode for a variety of application including domestic hot water and hydronic space heating. Recommended piping arrangement is shown in Figure 11 Maximum capacity through the CHRM is summarized in table 11; flows in excess of 60 GPM must be bypassed.

Figure 11 Typical Condensing System

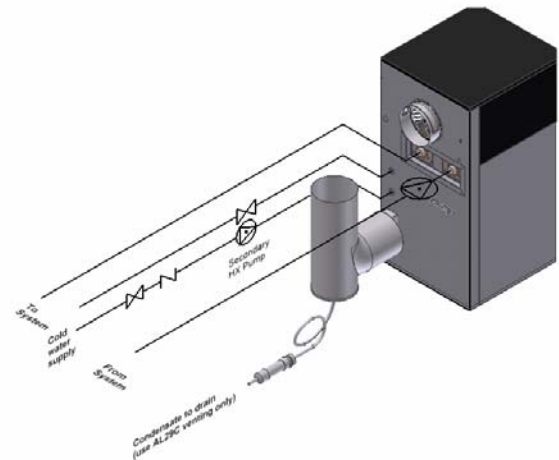

Condensate from the Dynaflame must be treated before being discharged to drain. PH level of the condensate is to be checked regularly and the neutralizing medium is to be replaced as required. A neutralizing cartridge is available from the factory. The condensing Dynaflame must be vented using only special venting type AL29-4C stainless steel or equivalent, please follow instructions detailed below.

When supplied with the CHRM, the DynaFlame is 95% efficient (category II or IV appliance) which requires the use of a special venting system fabricated from AL29-4C or equivalent material. Only venting components listed by a nationally recognized testing agency may be used.

This appliance may be installed with conventional, sidewall or vertical venting. Conventional vented appliances operate with negative pressure in the vent pipe and require a special vent adapter to increase the flue outlet diameter. Sidewall and vertically vented appliances operate with positive pressure in the vent pipe and may be directly connected to the flue outlet without the use of an increaser.

Consult the vent pipe manufacturer's instructions for minimum clearances to combustible material for vent components. In the absence of instructions, the minimum clearance to combustible material is six inches.

Consult vent pipe manufacturer's instructions for proper method of sealing vent pipe sections and fittings. In the absence of instructions, make sure that pipe and fittings are clean by swabbing with alcohol. Use Dow Corning 736 or 732 RTV, Polybar # 500 RTV or Sil-bond 4500 or 6500 to seal vent pipe. Do not use other sealants or adhesives except as expressly permitted by vent manufacturer's instructions.

Consult vent pipe manufacturer's instructions for vent system assembly. Follow vent pipe manufacturer's instructions if those instructions differ from this section.

Conventional Venting

Multiple appliances may be vented into a conventional chimney. The chimney must be lined with AL29-4C or equivalent and a single acting barometric damper must be provided for each appliance. Vent diameters are to be increased by one size over the recommended size downstream of the barometric damper.

A qualified professional using a proven vent-sizing program with input of accurate operating parameters must properly calculate sizing of the venting system. In applications where flue gas temperatures are lower than can support a Category II with conventional negative draft, it will be determined at the venting design stage that a positive pressure will be developed in the vent. It will then be necessary to either provide separate vents as for Category IV, to pressurize the boiler room, or to provide an extractor at the chimney outlet in order to maintain a negative draft in the chimney and allow common venting.

The chimney must be protected from down drafts, rain and debris by using a listed chimney cap. Approval of the installation will be at the discretion of authorities having jurisdiction.

Sidewall and Vertical Venting

The maximum vent length is 100 equivalent feet. Vent pipe may be run through a vertical or horizontal chase provided that minimum clearances to combustible materials are maintained. The vent should terminate a minimum 12 inches above grade plus normally expected snow accumulation, or 7 feet above grade if located adjacent to public walkways. Do not install over public walkway where local experience indicates condensation or vapour from the boiler creates a nuisance or hazard. Minimum 3 feet above any forced air inlet located within 10 feet of vent termination. Minimum 4 feet below, 4 feet horizontally or above any door window or gravity air inlet. Minimum 4 feet horizontally from electric meters, gas meters, regulators and relief valves. Use appropriately designed thimbles when passing through combustible walls or roofs. Install fire stops where vent passes through floors, ceilings or framed walls. The fire stop must close the opening between the vent pipe and the structure. Locate vent terminal above combustion air intake terminal (if used) and no closer than 2 feet vertically or horizontally. Vertical venting requires flashing and a storm collar to prevent moisture from entering the structure. Vertical vent termination must be at least 2 feet plus the expected snow accumulation above the roof penetration height.

4.9 CHRM, FLOW and PRESSURE DROP

Figure 12 – Secondary Heat Exchanger

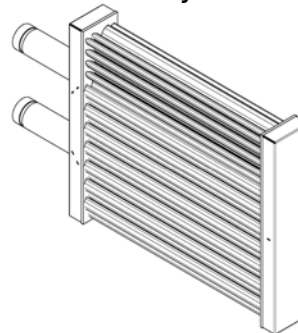

Table 11 – CHRM Head Loss & Flow for 10 °F Rise

Model	US GPM	ΔP - Ft.
500	10.0	0.4
750	13.0	0.7
1100	22.0	1.8
1200	24.0	2.1
1500	30.0	3.1
1750	35.0	4.2
2000	40.0	5.5
2500	50.0	8.0
3000	60.0	11.5
3500	*40.0	8.5
4000	*46.0	11.0
4500	*52.0	14.0
5000	*57.0	16.5

*Flow for 15°F rise at high fire

4.10 WATER FLOW SWITCH (shipped loose)

A water flow switch is shipped loose and is to be installed in the outlet piping on all heating boilers and hot water supply boilers. The flow switch is wired in series with the 24VAC safety control circuit. A diagnostic light will be indicated on the control display on a low flow condition.

4.11 LOW WATER CUTOFF (If Equipped)

If this boiler is installed above radiation level, a low water cut-off device must be installed at the time of boiler installation. Some local codes require the installation of a low water cut-off on all systems. Electronic low water cut-offs are available as a factory supplied option on all models. Low water cut-offs should be tested every six months. The normally open switch contact of the low water cutoff is to be wired in series with the flow switch. A diagnostic light will be indicated on the control display on a low flow condition.

Caution: remove jumper when connecting to 24 VAC circuit.

Figure 13 – Low Water Cut off Electrical Connections

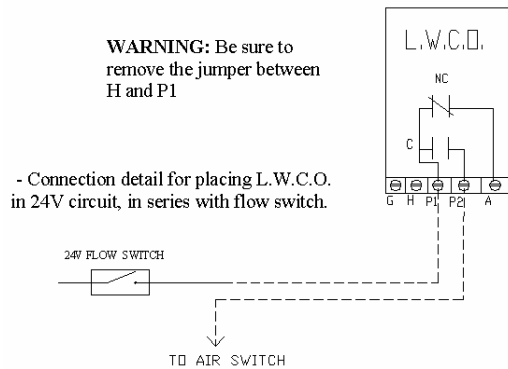

4.12 RELIEF VALVE (shipped loose)

This appliance is supplied with a relief valve sized in accordance with ASME Boiler and Pressure Vessel Code, Section IV (“Heating Boilers”). The relief valve is to be installed in the vertical position and mounted in the hot water outlet. No valve is to be placed between the relief valve, and the appliance. To prevent water damage, the discharge from the relief valve shall be piped to a suitable floor drain for disposal when relief occurs. No reducing couplings or other restrictions shall be installed in the discharge line. The discharge line shall allow complete drainage of the valve and line. Relief valves should be manually operated at least once a year.

CAUTION

Avoid contact with hot discharge water

4.13 CONDENSING HEAT RECOVERY MODULE PIPING CONFIGURATIONS

Caution: If isolation valves are provided on the CHRMs, the provision of a relief valve at the outlet of the secondary is recommended. This valve is to be sized at minimum for 10% of the input of the appliance and is to be piped to drain in a manner similar to the appliance relief valve.

4.13.1 CHRMs IN SERIES WITH PRIMARY HEAT EXCHANGER (INTEGRATED LOOP)

The supply water (Cold water) is pre-heated by CHRMs and fed into the outlet of the primary Heat Exchanger. Provisions must be made to prevent cold water below 110°F (44°C) entering to the Primary Heat Exchanger.

BOILER APPLICATION (HYDRONIC HEATING)

In case of boilers (Hydronic heating boiler) application, the return water (supply water) may be more than 110°F (44°C), therefore there is no need for a recirculation loop and the primary heat exchanger and CHRMs can be piped in parallel. Since the inlet water temperature to CHRMs exceeds 110°F (44°C) it will not condense fully and therefore the CHRMs will not perform to its maximum efficiency capacity. If water colder than 110°F (44°C) is available it can be fed to the CHRMs.

WATER HEATER APPLICATION (HOT WATER SUPPLY)

In case of domestic water supply (Water Heating), the fresh inlet water temperature will be less than 110 °F (44 °C), in

this case the CHRMs may be fed directly with part of the supply water using a secondary pump.

4.14 CIRCULATING PUMP SELECTION

The appliance has a low mass finned tube heat exchanger for fast response and high heat absorption and employs copper tubes for models DF-500 thru DF-3000 and copper nickel tubes for models Df-3500 thru DF-5000. Selecting the proper pump will ensure that temperature rise does not exceed 35°F (19°C) and that heat exchanger tubes are not prematurely scaled or eroded.

4.14.1 CIRCULATING PUMP OPERATION PRIMARY HEAT EXCHANGER

MOST IMPORTANT

This appliance is designed for continuous pump operation when the burner is firing. The circulating pump will run continuously when the power switch is in the “ON” position. As an optional feature a pump control system can be provided. The pump control option allows the appliance circulating pump to be cycled “ON” prior to the burner firing and cycled “OFF” some time after the set point is satisfied.

The operation of the circulating pump is controlled by the SmartFlame temperature control. When the appliance is activated by a remote operating signal the pump will start and run for the operating cycle and for a post purge period based on temperature difference between inlet and outlet connections to the appliance.

To select proper pump it is strongly recommended to consider following:

- Need to know the required flow (GPM) and pressure drop for your appliance (see table 4)
- Type of application, hydronic heating or Domestic Hot Water (DHW).
- For hydronic heating and DHW applications with normal water hardness choose a pump which will result in a temperature rise across the main heat exchanger of 30°F to 35 °F (17°C-19°C). If necessary use a flow setter valve to achieve the desired temperature rise.
- For DHW applications with other than normal water hardness choose a pump for the local water hardness conditions. When hardness levels exceed 17 grains per gallon consult factory for recommendations.

4.14.2 CIRCULATING PUMP SELECTION CONDENSOR

The operation of the circulating pump may be continuous or it may be in parallel with the main heat exchanger pump. Size the secondary pump for a minimum flow of 10% of the flow through the main heat exchanger and a maximum of 30% of the main heat exchanger flow up to 60 GPM.

PART 5 ELECTRICAL & CONTROLS

⚠ DANGER

IT IS EXTREMELY IMPORTANT THAT THIS UNIT BE PROPERLY GROUNDED!

5.1 ELECTRICAL CONNECTIONS

Minimum 120VAC 60Hz single phase (15A. circuit) is supplied to the control junction box models DF-500 through DF-2000 and 120VAC (20A circuit) models DF-2500 thru DF-3000 and 120/230VAC 60Hz single phase (20A circuit) models DF-3500 through DF-4000 and 120/230 VAC 60Hz single phase (30A circuit) models DF-4500 through DF-5000. The combustion air fan motor operates on 230 VAC, 3 ph, 60 Hz. This three phase voltage is generated by the variable frequency drive (VFD) and supplied directly to the fan motor. The appliance, when installed, must be electrically grounded in accordance with the requirements of the authority having jurisdiction or in the absence of such requirements, with the latest edition of the National Electrical Code ANSI/NFPA No. 70. When the unit is installed in Canada, it must conform to the Canadian Electrical Code, C22.1, Part 1 and/or local Electrical Codes.

- All wiring between the appliance and field installed devices shall be made with wire having minimum 220°F (105°C) rating.
- Line voltage wire exterior to the appliance must be enclosed in approved conduit or approved metal clad cable.
- The pump must run continuously when appliance is being fired.
- To avoid serious damage, DO NOT ENERGIZE the appliance until the system is full of water. Ensure that all air is removed from the pump housing and piping before beginning initial operation. Serious damage may result if the appliance is operated without proper flow.
- Provide the appliance with proper overload protection.

5.2 VARIABLE FREQUENCY DRIVE (VFD)

This appliance uses a Variable Frequency Drive (VFD) which provides power to the combustion fan. The fan motor operates on 230VAC 3 phase power. This three phase voltage is generated by the VFD and supplied directly to the fan motor. The VFD receives a modulating signal (4-20 mA or 2-10 VDC) from the local modulating control or a remote source based on water temperature to vary the frequency of the voltage supplied to the fan motor from 20 Hz up to 60 Hz. This varies the output of the combustion air fan from 20% up to 100% of capacity corresponding to the same variation in burner input. The VFD is driven towards 100% during the pre-purge portion of the start-up sequence. Once control self checks are completed, the VFD is provided with a signal to operate at soft start level for initial burner ignition. After main burner ignition is established, the modulating signal provided will use the VFD to vary the fan speed based VFD to vary the fan speed based on desired water temperature set point.

CAUTION

The voltage output from the variable frequency drive to the combustion air fan is 230VAC, 3 Phase. **AVOID** contact with high voltage wiring

5.3 DIFFERENTIAL AIR PRESSURE SWITCH

A differential air pressure switch is used to prove operation of the combustion air fan. The pressure switch sensing points are installed at the fan outlet as the air moves into the inlet of the burner. One point measures total pressure (+air) and is connected to a pitot tube facing the flow from the fan paddle wheel. The other point measures static pressure. Differential pressure at the switch will be affected by blockages at the fan inlet or at the flue discharge. A minimum differential pressure across the sensing points of the pressure switch proves operation of the combustion air fan. This is set in the factory and may be adjusted for field conditions. The diagnostics display will exhibit a Status of no Air Flow when the differential pressure switch detects a sustained low air condition. This condition could be caused by a number of factors including:

- Sensing line broken or loose fitting.
- Dirty filter or blocked vent.
- Steady high wind condition.
- Incorrectly set switch.
- Missing bleed restrictor at differential pressure switch on static pressure side air line (models DF-4500 & DF-5000).

5.4 HIGH and LOW GAS PRESSURE SWITCHS (Optional)

High and low gas pressure switches are available as an option and are wired in series with the air flow switch. The high gas pressure switch is used to monitor the differential gas pressure between the outlet of the control valve and the fan inlet. If differential gas pressure exceeds the maximum setting of the pressure switch, the appliance will shut down and a low air condition will be indicated on the display panel. The low gas pressure switch is to monitor the minimum incoming gas supply pressure supplied to the gas train. If gas pressure falls below the minimum setting of the pressure switch, the appliance will shut down and a low air condition will be displayed on the display panel.

5.5 HIGH LIMIT

A High Limit aqua-stat control is located at the back of the appliance and the control bulb is installed in a dry well in the heat exchanger header outlet. The setting of this control limits maximum discharge water temperature. A manual reset high limit will have a red reset button which must be pushed whenever water temperature has exceeded the set point of the manual reset limit. The temperature of the water in the heat exchanger must drop a minimum of 15°F (8.3°C) below the setting of the high limit control before the reset function can be activated. Whenever an appliance is supplied with both an auto reset and manual reset high limit always set the auto reset limit 10°F (5.5°C) below the manual reset limit. This will prevent nuisance tripping of the manual reset.

5.6 IGNITION CONTROL MODULE

This appliance uses a proven hot surface ignition control system. The operation of the electronic control module for the hot surface igniter proves the presence of an ignition

source much like a proven standing pilot before the gas valves are energized. The ignition control proves the presence of the proper ignition temperatures from the hot surface igniter using a proof current (2.7A +/- 0.2), energizes the main gas valves, proves the presence of main burner flame, and provides for lockouts. A status point alarm of Flame Fail will be displayed on the main panel and also by 3 flashes from the ignition module diagnostic red LED

Figure 14 – Ignition Module

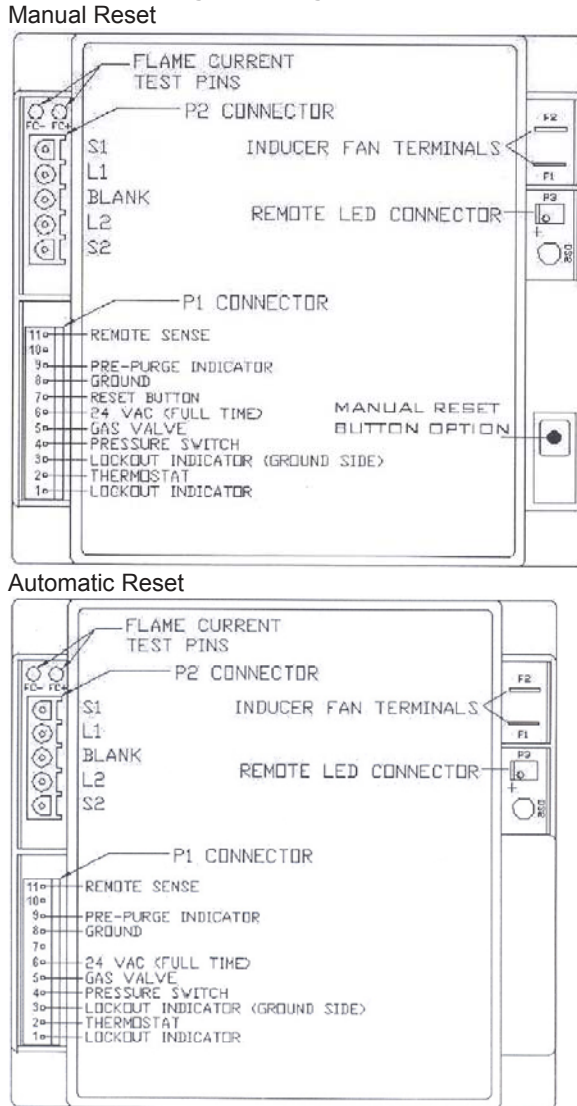

5.6.1 SERVICE PARTS

This appliance uses a proved electronic ignition control module and a hot surface igniter. The electronic ignition module is not repairable. Any modification or repairs will invalidate the warranty and may create hazardous conditions that result in property damage, personal injury, fire, explosion and/or toxic gases. A faulty hot surface igniter or ignition module **MUST** be replaced with a new factory approved unit only. A factory approved igniter, ignition control module and flame sensor for this specific unit is available from your local distributor. **DO NOT** use general purpose field replacement ignition modules, igniters or sensors. Each appliance has one ignition module, one hot surface igniter and one flame sensor.

5.6.2 IGNITION MODULE LOCKOUT FUNCTIONS

The ignition module may lockout in either a hard lockout condition requiring pushing of the reset button to recycle the control for a CSD1 requirement or a soft lockout condition which may be reset by momentarily cycling the main power on and off. A typical hard lockout fault for the 7 seconds one try CSD1 module is a flame failure condition. Pushing the reset button on the ignition control is the only way to reset an ignition module that is in a hard lockout condition. The reset button is located on the front control panel. The reset button is active after the post purge cycle when there is a hard lockout condition as indicated by the Status LED (3 flashes). Turning the main power “OFF” and then “ON” or cycling the thermostat will not reset a hard lockout condition. Wait five seconds after turning on the main power before pushing the reset button when the ignition module is in a hard lockout. Wait for the status LED to glow solid red indicating that the ignition module is ready before releasing the reset button.

The ignition module will go into a soft lockout with the standard 10 seconds module after three sequential trials for ignition separated by 15 seconds between trials. A soft lockout condition will operate the combustion air fan for the post purge cycle (maximum 10 minutes) and then go into lockout and stay in this mode with the air flow light “OFF”. The flame failure and all other lights up to the air flow light will remain “ON”. If the control sensed fault is not corrected, the ignition module will continue in the soft lockout condition. A soft lockout condition may be reset by manually cycling the electronic thermostat or turning the main power switch “OFF” and then “ON” after the control sensed fault has been corrected.

5.6.3 DIAGNOSTIC STATUS INDICATION

The ignition module has an LED that indicates the status of the ignition safety circuits. The flashing operation of this LED indicates the diagnostic status of the ignition control module. The following listing gives the flashing diagnostic status codes as signaled by the ignition module.

Table 12

CODE	CONDITION
• LED constant on	System OK – no faults present
• LED off	Possible control fault – check power or no call for heat.
• 3 flashes	Ignition lockout
• 6 flashes	Internal fault replace control

5.6.4 FLAME SENSE TEST

Figure 15 – Ignition Module Flame Sense Test

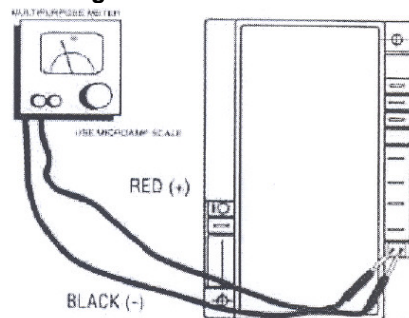

Using a μ A meter the flame signal can be measured with the appliance running. The ignition modules requires

minimum 2.0 μ A D.C. If the signal is less than this it could indicate oxide on the metal rod, a partial ground through the ceramic insulator or an improperly placed sensor. If oxide is evident on the sensing rod use steel wool to remove it. Do not use emery paper since the silica will foul the sensor surface.

PART 6 CONTROL PANEL

6.1 APPLIANCE TEMPERATURE CONTROLLER

The appliance is provided with a control panel at the front. Operating controls are installed inside the control box and are accessible by undoing the thumb screw and swinging opening the door. The diagnostic information centre as well as the on/off switch, 24V fuse, and the appliance temperature controls reside on the control box door the ignition control module, VFD, transformer and relays are mounted on the internal panel.

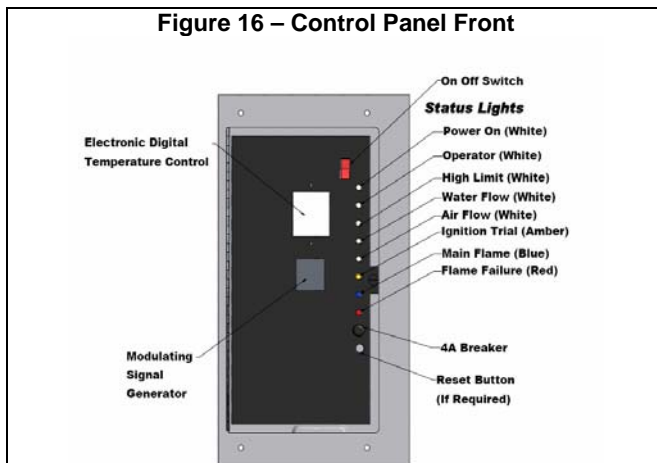
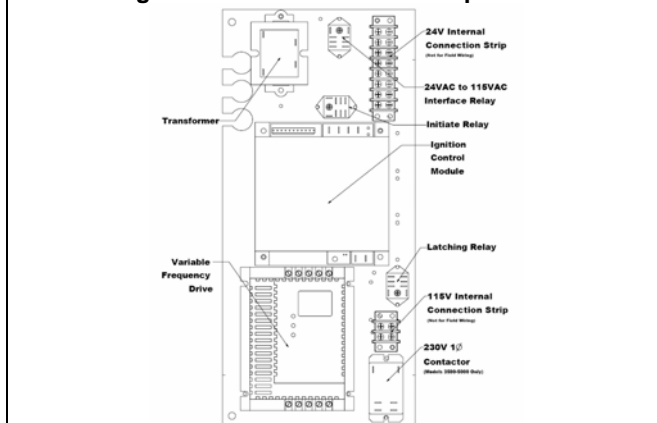

Figure 17 – Control Panel Components



The Boiler Temperature Controller (BTC) for this appliance is a Camus 780014 SmartFlame control. It initiates the local call for heat and sets the target return (appliance inlet) water temperature. This controller accommodates up to 2-stages of control with six modes of operation which provides set point as well as reset control. It provides the following:

- Readings of inlet and outlet water temperatures as well as Δ T temperature rise.
- Six pre-set modes of operation; mode 1 for heating and

constant circulation DHW, modes 2, 4, and 5 for heating, mode 3 for DHW with remote sensing and mode 6 for operation by a remote controller.

- Operation as an auto reset limit.
- Operation as a control for inlet water temperature.
- Optional tank mounted sensor used in conjunction with inlet sensor.
- Adjustable pump delay feature based on Δ T temperature difference between inlet and outlet temperatures. Accepts 1/6 hp. pump directly across terminals 13 & 14. An optional 3/4 HP relay is available.
- Adjustable; target temp, inter-stage differential, on delay between stages, minimum on time per stage, minimum off time per stage.
- Display of run hours for maintenance purposes. Counter wraps around at 1000 hours. Pressing and holding up and down arrow key simultaneously will reset the counter.
- Flame failure signal 24V.
- Molex connector for ease of service.
- Error message display.
- Test override feature to test pump operation, stages 1, 2, and alarm. Press and hold the UP button to test. After one second the pump will turn ON. Stage 1 will turn ON after four seconds. Stage 2 will turn ON after seven seconds. Alarm will turn ON after ten seconds. The controller will return to normal operation after releasing the UP button.
- Pump exercising feature runs pump 10 seconds every three days of no pump operation.

Setting the Appliance Temperature Control

Press and hold the ITEM, UP and DOWN buttons simultaneously for 3 seconds. The appliance will shut down. Press the ITEM key and then select the desired setting using the UP, DOWN buttons. Pressing the ITEM key again will cause the last setting to be accepted. Once all settings have been made, wait for 30 seconds for the control to return to normal operating mode. In normal operating mode the inlet temperature, outlet temperature, Δ T temperature and ON hours can be viewed by repeatedly pressing the ITEM key only. If you wish to check the setting you will have to start again by pressing and holding the ITEM, UP and DOWN buttons simultaneously for 1 second, and then use only the ITEM key to scroll through the settings. After checking the settings allow the control to return to normal operation on its own. Default display is outlet temperature.

Mode 1 is intended for constant temperature hydronic heating using proportional logic. The set-point for inlet water control is pre-set to 180°F and the auto re-set limit is set to 230°F. The inlet set-point can be adjusted, however the limit is fixed. In addition to the auto reset limit the factory installs a manual re-set limit set to 250°F. The control turns on the appliance pump and stages the appliance to maintain set-point target temperature at the **appliance inlet** whenever an external heat demand is present. Once the external heat demand is removed, the control turns off the appliance and operates the appliance pump based on the purge feature. This mode can also be used for process DHW applications. If the pump runs continuously there will not be a need for an external heat demand.

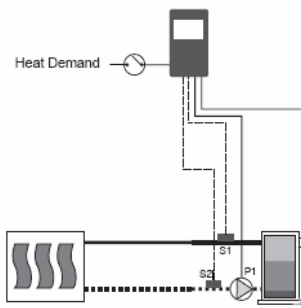

Mode 2 is intended for hydronic heating based on PID logic. The set-point for supply water sensor S3 is pre-set to 180°F and the auto re-set limit is set to 230°F. The supply sensor set-point can be adjusted, however the limit is fixed. In addition to the auto reset limit the factory installs a manual re-set limit set to 250°F. The control turns on the appliance pump and stages the appliance to the set-point target temperature at the **system** temperature whenever an external heat demand is present. Once the last appliance stage turns off and the heat demand is still present, the control then operates the appliance pump based on the purge feature. In this case, it is imperative that the system pump operates continuously in order to provide constant circulation past the system sensor. The appliance pump then turns back on with the first stage of the appliance. If the heat demand is removed, the appliance is turned off and the control operates the appliance pump P1 based on the purge feature.

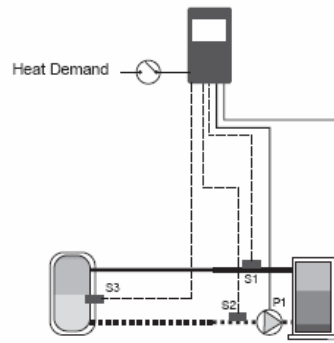

Mode 4 is intended for hydronic heating. The set-point for inlet water control is pre-set to 180°F and the auto re-set limit is set to 230°F. The inlet set-point can be adjusted, however the limit is fixed. In addition to the auto reset limit the factory installs a manual re-set limit set to 250°F. The control turns on the appliance pump and stages the appliance to maintain outdoor reset target temperature at the **appliance** inlet sensor S2 whenever an external heat demand is present. Once the external heat demand is removed, the control turns off the appliance and operates the appliance pump based on the purge feature.

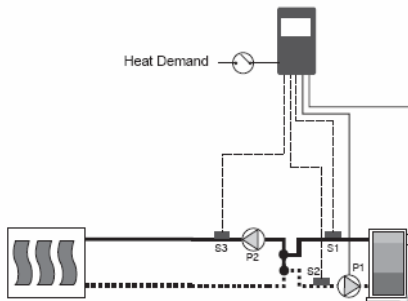

Mode 3 is intended for domestic water heating. The set-point for inlet water control is pre-set to 140°F and the auto re-set limit is set to 200°F. The inlet set-point can be adjusted, however the limit is fixed. In addition to the auto reset limit the factory installs a manual re-set limit set to 210°F. The control turns on the appliance pump and stages the appliance to maintain set-point target temperature at the **appliance** inlet temperature. An internal demand is generated from the DHW sensor which could be placed in the storage tank while the external heat demand is permanently wired or through a timer. Once the DHW tank is satisfied (internal demand is removed), the control turns off the appliance and operates the appliance pump based on the purge feature.

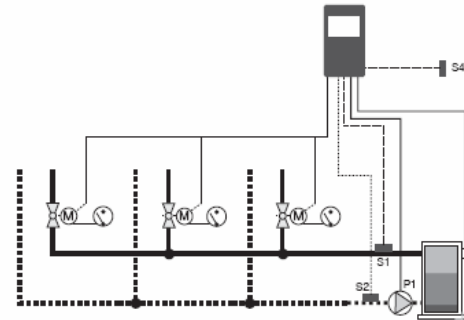

Mode 5 is intended for hydronic heating. The set-point for inlet water control is pre-set to 180°F and the auto re-set limit is set to 230°F. The inlet set-point can be adjusted, however the limit is fixed. In addition to the auto reset limit the factory installs a manual re-set limit set to 250°F. The control turns on the appliance pump and stages the appliance to maintain outdoor reset target temperature at the **system** sensor S3 whenever an external heat demand is present. Once the last appliance stage turns off and the heat demand is still present, the control then operates the appliance pump based on the purge feature. In this case, it is imperative that the system pump operates continuously in order to provide constant circulation past the system sensor. The appliance pump then turns back on with the first stage of the appliance. If the heat demand is removed, the appliance is turned off and the control operates the appliance pump based on the purge feature.

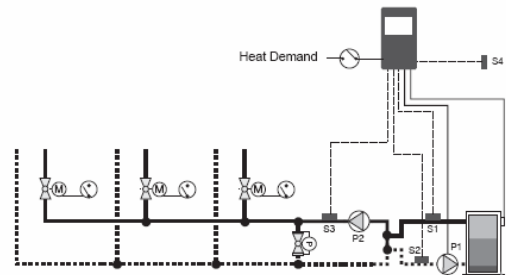

Mode 6 is intended for multiple appliance application and all stages are closed at all times. In essence there is no operator at the appliance. A removable jumper is provided

in the electrical enclosure across the contacts to be used for connection to the remote operator. The fixed auto re-set limit is set to 230°F. In addition to the auto reset limit the factory installs a manual re-set limit set to 250°F. The control provides pump operation. Staging operation is provided by an external sequencing control. Heat demand is provided to the external sequencing control. External sequencing control then provides heat demand to the control. Each control turns on its respective appliance pump and stage 1 contact whenever an external heat demand is present. Once the external heat demand is removed from the control, the control turns off the stage 1 contact and operates the pump to provide purging. Once the purge period is complete, the control turns off the appliance pump.

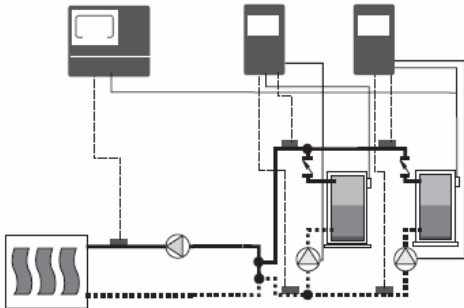

CAUTION

If this setting is inadvertently chosen the appliance will cycle on the limits. There is a danger of scalding if this setting is used in a DHW application.

6.2 MODULATING SIGNAL GENERATOR

This controller is located below the appliance temperature controller. Once a call for heat has been initiated by the appliance temperature controller this control generates a modulating signal (4 – 20 mA or 2 – 10 VDC) based on return water temperature. After completion of factory settings the lock feature permits adjustment of set point only (SV). This setting is normally 5°F below the appliance temperature controller setting. In this way the firing rate of the boiler will be at minimum when return water temperature is 5°F below target. The modulating signal generator has separate settings for domestic and hydronics applications and is factory set as shown below:

Table 13

	DOMESTIC HOT WATER	HYDRONIC HEATING
P-n1	0	0
P-n2	1.0	1.0
P-df	1.0	1.0
P-SL	32	32
P-SU	160	220

LOC FEATURE:

- ❖ 1 - locks in all settings
- ❖ 0 - allows adjustments to all settings
- ❖ 2 - allows adjustment of set point only

6.3 VARIABLE FREQUENCY DRIVE (VFD)

The VFD has a factory set security code which has to be entered before any adjustments can be made. The VFD has 50 parameters, which can be adjusted. At present only the following are pertinent:

Table 14

Parameter #	Function	Settings
2	Carrier Frequency	03
4	Stop Method	03
5	Standard Source	Speed 04 (03 for 2- 10 VDC)
19	Acceleration Time	120 sec
20	Deceleration Time	60 sec
28	Fixed Boost	1.0
36	Preset Speed	29
38	Skip Bandwidth	3.0
45	Speed at Minimum Signal	32 (25 for condensing)
50	Fault History	View Only
51 thru 58	Miscellaneous	View Only

PART 7 COMPONENTS

7.1 HOT SURFACE IGNITER (GLOW BAR)

The silicon carbide igniter is inserted directly through the fan flange and held in place by two screws. A hold down bracket as well as sealing gasket above and below the igniter assures a good seal. Care must be taken when removing and/or installing the igniter since the silicon carbide element is brittle. Always remove the igniter prior to removing the fan assembly for inspection of the burner and heat exchanger. Properly prepared igniter will have a bead of silicone sealing the end mounting bracket to the ceramic shaft.

Figure 18 – Hot Surface Igniter

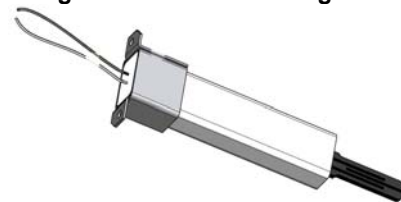

During trial for ignition a properly operating igniter will generate 3A which is the proof current required by the ignition module for reliable and consistent operation. It is recommended that the hot surface igniter be replaced every 4,000 hours of appliance operation to maintain peak ignition efficiency.

7.2 FLAME SENSOR

The flame sensor is inserted directly through the fan flange and is screwed into the fan flange. Care must be taken, when installing the flame sensor, to align it perpendicular to the fan flange and parallel to the burner tube and not to over tighten. Always remove the flame sensor prior to removing the fan assembly for inspection of the burner and heat exchanger.

Figure 19 – Flame Sensor

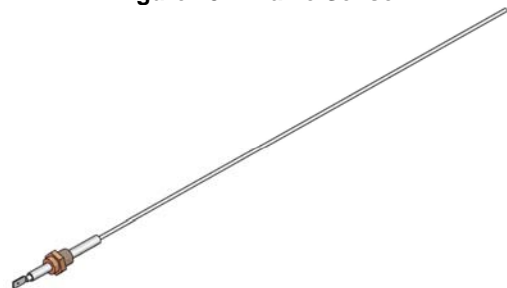

The ignition module relies on the flame sensor to provide a flame rectification signal. Oxide deposits, improper placement or damaged ceramic insulator will result in insufficient signal leading to ignition module lock out. For proper operation minimum 2.0 μ A DC must be fed back to the module. Oxide deposit on the sensor rod must be removed with steel-wool. Do not use sand-paper since this will contaminate the surface.

7.3 COMBUSTION AIR FAN

Figure 20 – Fan, Burner, Hot Surface Igniter and Flame Sensor Arrangement



DynaFlame uses a sealed air fan to provide combustible air/gas mix to the burner and push the products of combustion through the heat exchanger and venting system. The fan assembly consists of a sealed housing and fan wheel constructed from spark resistant cast aluminum. The fan is operated by a fully enclosed 230 VAC, 3 Phase electric motor. The fan housing and motor assembly is fully sealed and SHOULD NOT be field serviced. The power draw of the motor is proportional to the modulated gas input rate of the appliance.

7.4 INNER JACKET

The inner jacket assembly is constructed from a special corrosion resistant stainless steel. This includes both the primary heat exchanger chamber and the secondary heat exchanger chamber. All screws and fasteners used for assembly of the inner jacket and secondary heat exchanger chamber are also stainless steel.

DO NOT mix stainless steel and standard plated fasteners when disassembling and reassembling the inner jacket sheet metal components. Standard plated fasteners will be damaged by the flue product condensate when used on the inner jacket assemblies.

7.5 OUTER JACKET

The outer jacket assembly is constructed from mirror finish stainless Steel. This ensures a long life for the jacket assembly, with full integrity

7.6 VENTING TRANSITION

All appliances are shipped with a rectangular to round stainless steel adapter. Depending on the appliance category an increaser will be required for the proper vent configuration. Please refer to table #3 dimensions and specifications.

When installing Category II or IV appliances care must be taken to properly seal all joints and provide slope for drainage of condensate.

PART 8 FIELD STARTUP PROCEDURE

8.1 CHECKING THE INSTALLATION

- Inspect the connections for water, gas and electricity.
- Confirm that water is being pumped toward the heat exchanger inlet. Never pump away from the exchanger since this will result in a low-pressure zone, which will allow localized boiling and result in heat exchanger damage.
- Power to the boiler and pump must be from the same circuit to prevent the boiler firing in case the pump is inadvertently shut off.
- Inlet gas pressure must be a minimum of 3" W.C. for natural gas and 11" W.C. for propane.
- With the boiler off, open the main gas supply valve and vent the trapped air from the piping leading to the boiler. Confirm that all gas connections to the heater are tight and that there are no missing test plugs.
- Connect a manometer to obtain the differential air pressure between negative and positive ports. See Figure #3.
- The air/gas ratio controller automatically adjusts to match the air signal on the gas side. In this way true mass flow control of air/gas mix is achieved. Typical differential air settings are listed in Table 8. All boilers are test fired and factory set. A test sticker with actual reading is affixed to the unit. In general, these readings will be within 0.3" W.C. of the readings shown in Table 8.

Refer to Part 3 of the manual for recommendations on setting combustion characteristics.

8.2 CHECKING THE CONSTRUCTION

- Check the boiler wiring to see that it agrees with the wiring diagram supplied.
- Confirm that all terminal strips and field connections are identified.
- Confirm that the SmartFlame control is set in the proper mode. In remote mode an external controller determines the set point and the stage contacts on the SmartFlame are always closed. Auto reset limits are fixed in all Modes.
- With the firing valve in the off position, switch on power to the boiler. The indicator lights will sequentially energize to show that the operator, limit control and water flow are functioning properly. The fan motor will accelerate until the airflow light energizes. If a light remains off, the ignition sequence will not proceed. During trial for ignition the red flame failure light may light up momentarily.
- Once all lights are energized the ignition module will try for ignition. When the igniter is hot enough, the ratio gas valve actuator is energized and if ignition is accomplished the blue main burner light will come on and remain lit. If ignition is not accomplished, the red flame failure light will energize and two more ignition trials will be made 15 seconds apart. The control will then proceed to lockout and must be reset by momentarily interrupting power. It is normal during

initial start up, when air is being purged from the piping, to require two to three tries before successful ignition.

- With the boiler running, check for flue gas leaks along the inner cabinet joints and around the flue outlet. Some minor leakage is acceptable.
- Repair any major leaks prior to proceeding to the next step.
- At the factory adjustments were made to achieve proper input and acceptable burner performance at full input and at minimum input.
- Depending on field conditions, the CO₂ trim valve may require some minor adjustment at full input. Refer to Figure #3. Always set the appliance for a CO₂ level in the range of 7.5% to 8.0%. Adjustment at minimum input can be done at the low fire adjustment screw by first removing the brass cap. Turning adjustment screw clockwise will increase CO₂.

8.3 FIRE TESTING

- This boiler is designed for low fire soft start. At the start of trial for ignition the fan will decelerate to minimum fire and will light off at low fire before ramping up towards full input depending on the 4 – 20 mA signal from the controller.
- Shut power off to the heater and open the firing valve. Switch power back on and allow the burner to fire. Ignition should be smooth with typical differential air pressures as shown in Table 8: Normally the differential gas pressure will be identical to the differential air pressure. Actual differential pressure may vary from above numbers due to the field conditions and sample variations. Always make adjustments to meet the recommended CO₂ levels. Adjust high fire first followed by adjustment to the low fire settings.
- Check combustion. For natural gas the CO₂ reading at full fire should not exceed 8%. At low fire, CO₂ will be between 7% and 7.5%. For propane, reading will be approximately 1.5% higher.
- Allow the water temperature to rise so that the heater cycles on the operator.
- Check the temperature rise across the heat exchanger. This will be item ΔT on the SmartFlame control. For hydronic applications and for domestic hot water, a rise exceeding 35°F is not normally recommended. After confirming temperature rise, set the control to the "OUT" temperature display using the item key.
- Allow the unit to cycle on the limit. This can be done by gradually restricting outlet water flow. The auto reset limits are set at 200°F for domestic hot water and 230°F for hydronic heating. In addition the heaters are equipped with a manual reset high limit set at 210°F for domestic hot water and 250°F for hydronic heating. After confirming limit operation return the control to the "IN" temperature display.
- Remove fan inlet filter. During trial for ignition, block 75% of the fan inlet opening. The air flow light should de-energize. If it does not, slowly turn the adjustment screw clockwise until the light de-energizes.
- Check the differential pressure switch. Remove the restriction from the fan inlet and reset the power on the control panel. A properly set air switch will cause the air flow light to energize at a fan speed between 15Hz and 20Hz on the VDF.
- Check the ignition retries circuit.

- Shut the main gas off to the unit and allow it to try for ignition. Trial for ignition should commence within 30 seconds.

8.4 COMMISSIONING APPLIANCE

- Remove manometers and replace inlet gas pressure test plug.
- Fill out start up report for each heater. Be sure to record all settings and readings. Retain a copy of report for future reference.
- Start up is now complete and heater may be placed into service.

PART 9 TROUBLE SHOOTING

Note: Before troubleshooting, familiarize yourself with the field startup procedure.

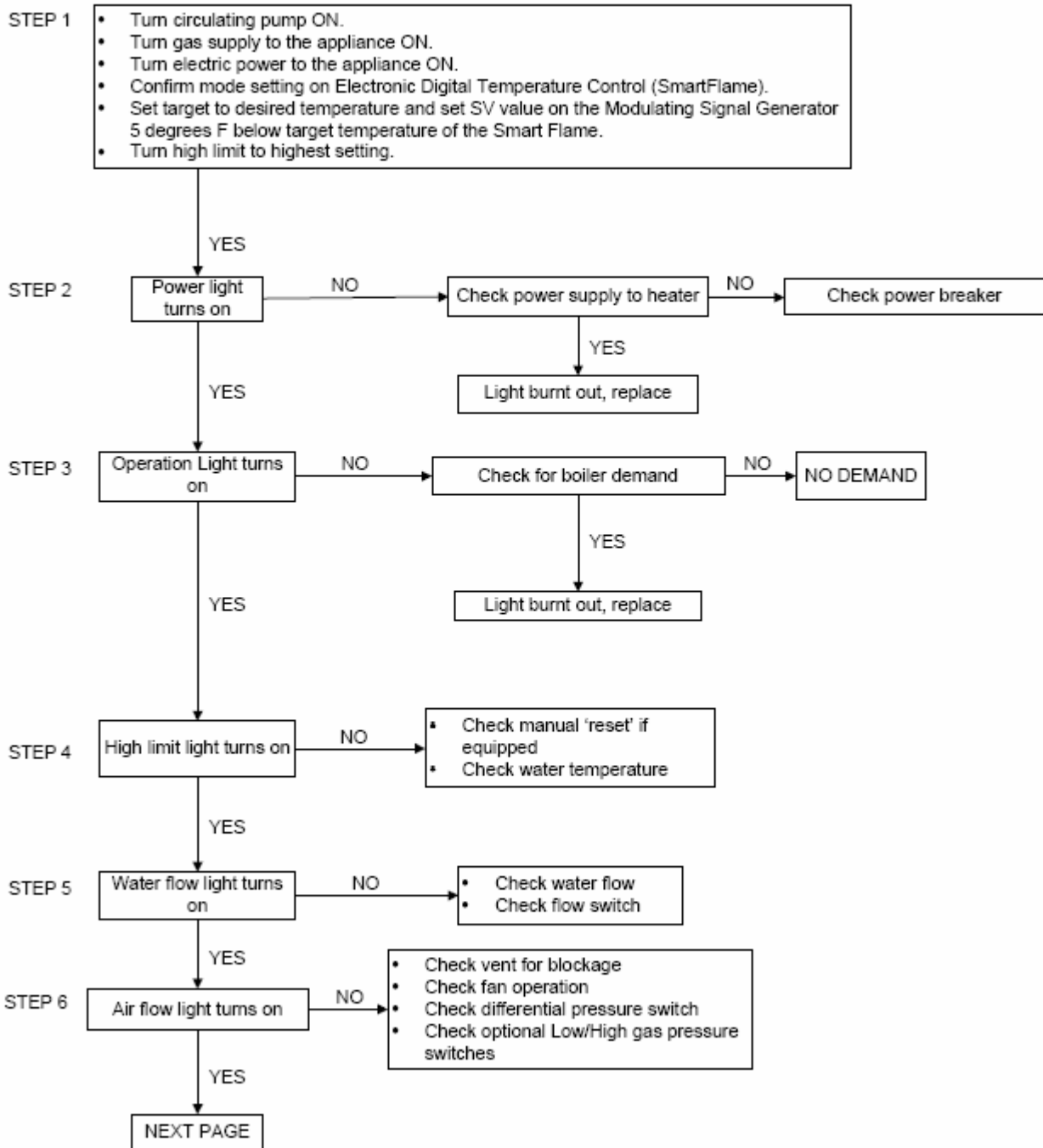

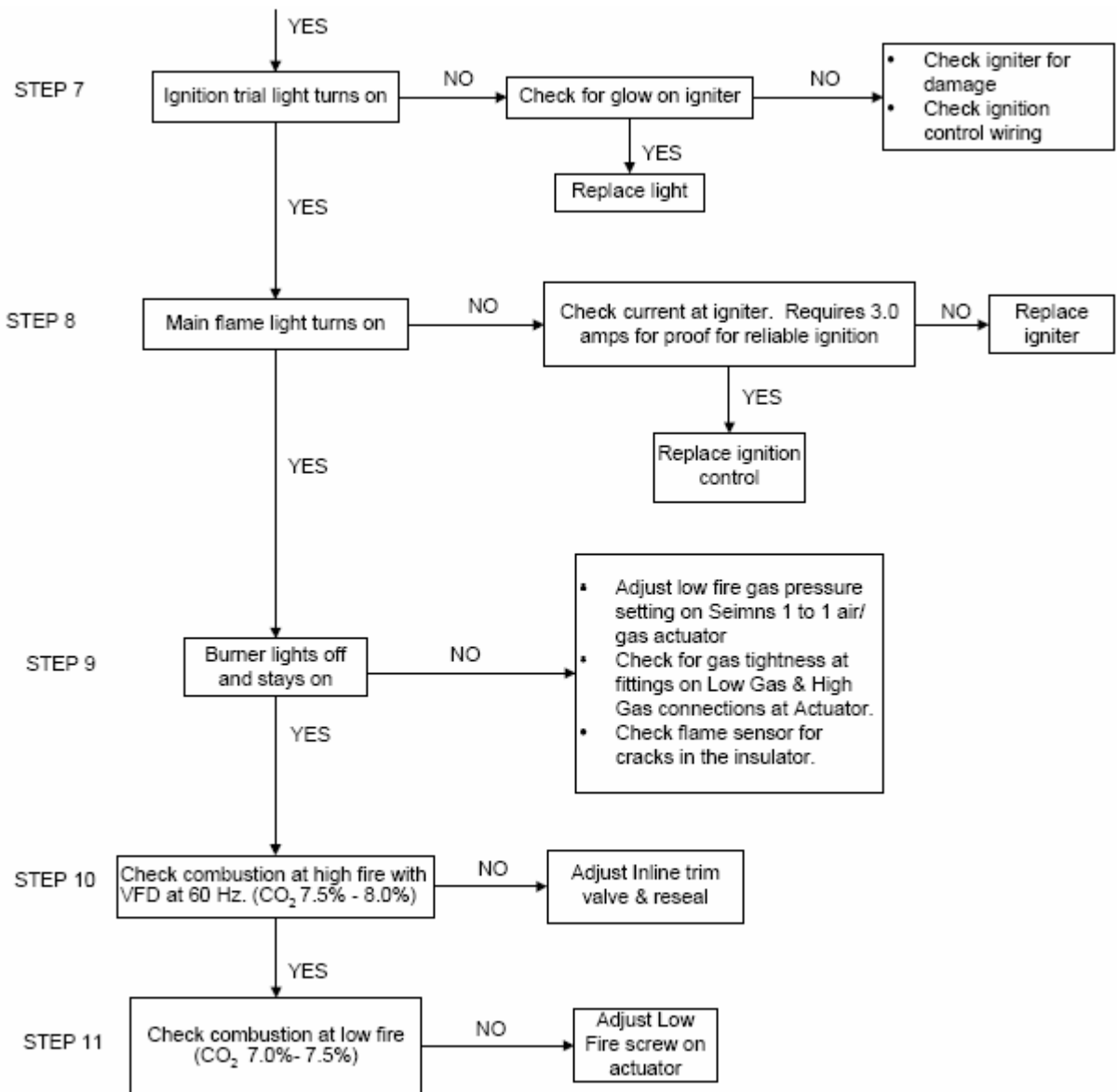

PART 10 MAINTANANCE

CAUTION

It is important that all gas appliances to be serviced by a competent person. It is in your own interest and that of safety to ensure that all local codes, and all the "NOTES" and "WARNINGS" in this manual are complied with. To service or adjust this appliance, it is imperative that the competent serviceman utilize a combustion analyzer to read CO₂, CO and flue pressure according to Camus Hydronics recommendation

CAUTION

Label all wires prior to disconnection when servicing controls. Wiring errors can cause improper and dangerous operation

Listed below are items that must be checked to ensure safe reliable operations. Verify proper operation after servicing.

10.1 EXAMINE THE VENTING SYSTEM

Examine the venting system at least once a year. Check more often in the first year to determine inspection interval. Check all joints and pipe connections for tightness, corrosion or deterioration. Flush the condensate drain hose with water to clean. Clean screens in the venting air intake system as required. Have the entire system, including the venting system, periodically inspected by a qualified service agency.

10.2 VISUALLY CHECK MAIN BURNER FLAMES

At each start up after long shutdown periods or at least every six months. A burner view port is located on the burner mounting flange.

CAUTION

The area around the burner view port is hot and direct contact could result in burns

Figure 21 – Normal Burner Flame Profile (short dense and blue)

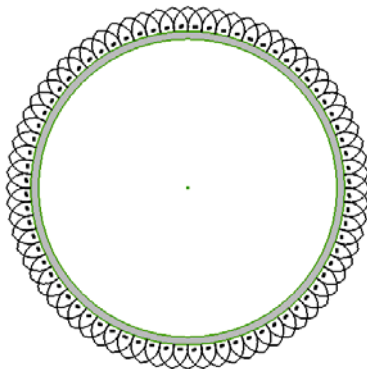

- Normal Flame: A normal flame at 100% of burner input is blue, with slight yellow tips a well defined flame and no flame lifting.
- Yellow Tip: Yellow tipping can be caused by blockage or partial obstruction of air flow to the burner.
- Yellow Flames: Yellow flames can be caused by blockage of primary air flow to the burner or excessive gas input. This condition **MUST** be corrected immediately.

- Lifting Flames: Lifting flames can be caused by over firing the burner, excessive primary air or high draft in excess of negative 0.15" W.C.

If improper flame is observed, examine the venting system; ensure proper gas supply and adequate supply of combustion and ventilation air.

10.3 FLUE GAS PASSAGEWAYS CLEANING PROCEDURES

Any sign of soot around the inner jacket, outer jacket, flue pipe connections, burner or in the areas between the fins on the copper heat exchanger indicates a need for cleaning. The following cleaning procedure must only be performed by a qualified serviceman or installer. Proper service is required to maintain safe operation. Properly installed and adjusted units seldom need flue cleaning.

NOTE:

All gaskets/sealant on disassembled components or jacket panels must be replaced with new gaskets/sealant on re-assembly. Gasket and sealant kits are available from the factory

CAUTION

When the vent system is disconnected for any reason it must be reassembled and resealed according to vent manufacturer's instruction

10.4 CONDENSATION TREATMENT

This high efficiency appliance may operate as a condensing appliance for extended periods of time based on return water temperatures. Condensate occurs when the products of combustion are cooled below their dew point in the heat transfer process. The liquid condensate formed from this high efficiency heat transfer process is mildly acidic. The condensate will typically have a pH ranging from 4.0 to 5.0 as it is discharged from the condensate drain on the rear of the appliance. The internal jacket area where the condensate is collected (CHRM) is constructed from a special corrosion resistant stainless steel. All materials external to the appliance in contact with the condensate must be corrosion resistant. This is typically accomplished by using PVC plastic pipe and synthetic tubing. Condensate must be able to flow freely from the appliance. All condensate flow is accomplished by gravity requiring a minimum downward slope of 1/4" per foot (21mm/m) to ensure proper flow to the condensate management system and/or a suitable drain. The neutralizer **MUST** always be mounted on the same level or lower than the bottom of the appliance cabinet. All condensate piping and connections must be easily accessible for routine maintenance and inspection.

10.4.1 CONDENSATE VOLUME

There are several factors effecting amount of condensation created by the appliance CHRM, however for rough approximation use.

Condensation Volume, US Gallon/Hr = Input, MBH/1000 x 5.0

Many codes will require the acidic condensate to be neutralized before it can be placed in a drain system. A neutralizer to control the pH of the liquid discharged to a drain system is provided with every condensing appliance. The neutralizer consists of an industrial grade, non-corrosive plastic reservoir for collection of the condensate. The condensate collects in the reservoir where it is in direct contact with the calcium carbonate. As the reservoir fills, it provides an extended residence time to neutralize the condensate. The neutralized condensate exits from the reservoir outlet. A 'P' trap must be installed upstream of neutralizer see Figure 2 above. Prime the installed assembly with water to prevent flue gas spillage from the drain. Use standard ½" vinyl, PVC, CPVC or suitable hose to run to floor drain.

When the condensate level in the reservoir rises to the drain, the pH is controlled to a range of 6.2 to 6.5 before exiting the system. (A pH of 7 is neutral. As the pH number increases in numerical value, the relative acidity of the discharge decreases). The neutralized condensate may then be discharged into a suitable drain system without fear of damage to the drain system. Always check with local codes for specific requirements. Neutralizers may be used in series to raise PH.

10.5 BURNER MAINTENANCE

The burner should be removed for inspection and cleaning on an annual basis. An appliance installed in a dust or dirt contaminated environment will require inspection and cleaning on a more frequent schedule. The fan assisted combustion process may force airborne dust and dirt contaminants, contained in the combustion air, into the burner. With sustained operation, non-combustible contaminants may reduce burner port area, reduce burner input or cause non-warrantable damage to the burner.

Airborne contaminants such as dust, dirt, concrete dust or dry wall dust can be drawn into the burner with the combustion air and block the burner port area. An external combustion air filter is provided with the appliance. An additional filter is located at the fan inlet and like the external filter may be washed in the sink under the tap. This internal filter should be checked and cleaned at the time of appliance commissioning and on a six month interval or more often in a contaminated environment.

10.5.1 BURNER REMOVAL AND CLEANING

Access to the burner will require the following steps:

- Turn off main electrical power to the appliance.
- Turn off main manual gas shutoff to the appliance
- Remove the top cover.
- Disconnect the gas supply connection to the fan inlet.
- Disconnect the fan motor power wires at the harness.
- Remove the hot surface igniter and the flame sensor.
- Remove the sensing tubes from the air ratio gas valve to the combustion air fan.
- Remove the 4 nuts holding the fan assembly to the heat exchanger and remove the fan assembly. On occasion the red silicone gasket may adhere to the underside of the fan's flange. Carefully pry the

flange away from the gasket prior to removing the fan assembly.

- The burner can now be lifted vertically out of the heat exchanger cavity. A ceramic paper gasket is located directly under the burner flange. This gasket must be replaced if it is damaged.
- Use care to prevent damage to the knitted metal fiber of the burner surface.
- Wash the burner with low pressure water. Never wipe or brush the surface of the burner.
- Check all gaskets and replace as necessary. Gaskets affected by heat will not reseal properly and must be replaced.
- Replace the burner in the reverse order that it was removed. Insert the igniter and sensor before doing the final tightening on the fan mounting nuts. Evenly tighten the nuts to 20 ft-lbs.

NOTE:

When the combustion air fan is removed for any reason, the inlet to the burner must be covered to prevent further foreign objects from falling into the burner. Always look inside the burner to check for dents. Do not place a burner back into operation if the inner distribution screen has been dented during the service operation, call the factory for recommendations. Use care when removing and handling the burner, Sharp objects or impact may damage or tear the metal fiber surface rendering the burner unfit for service.

10.5.2 BURNER CLEANING PROCEDURE

Remove any visible dust or dirt blockage from the surface of the burner using water from a garden house. The burner may best be cleaned by immersing the burner port area in a solution of dishwashing detergent and hot water. Do not use chlorine based solvents or cleaning agents on the burner. Allow the burner to remain in the solution for a short period of time to remove dust, dirt and oil or grease laden contaminants. Rinse the burner thoroughly with clean water to remove any residue from the detergent cleaner. The burner should be air dried after removal from the cleaning solution and rinsing.

10.6 CHANGING THE HOT SURFACE IGNITER

- The hot surface igniter is to be checked at least after every 4000 hours of operation and more frequently under high cycling conditions. This will maintain peak ignition efficiency.
- Turn off main electrical power to the appliance.
- Turn off main manual gas shutoff to the appliance.
- Locate the Hot Surface Igniter.
- Disconnect the two power leads to the hot surface igniter.
- Loosen and remove the two screws that hold the igniter.
- Lift the igniter vertically out of the burner mounting flange. Use care, do not hit or break the silicon carbide igniter.
- Ensure that the ceramic paper gaskets used to seal the base and top of the igniter are reinstalled on the new igniter.

10.6.1 RE-INSTALLING THE IGNITER

- Confirm that the end of the replacement igniter has a bead of silicone sealing the gap between the metal mounting flange and the ceramic shaft of the igniter.
- Carefully insert the igniter into the mounting point on the burner flange and push into position on top of the fan's flange.
- Reinstall the two mounting head screws and tighten by hand only.
- Ensure that the igniter ceramic paper gaskets are properly installed and seal the point of contact between the igniter and fan mounting flange.
- Reconnect the power leads to the igniter.
- Turn on main gas supply.
- Turn on main power.
- Test fire the appliance to ensure proper operation.
- The igniter must generate 3A to reliably prove the ignition system.

10.7 PRIMARY HEAT EXCHANGER INSPECTION

- The primary heat exchanger should be inspected at the time of burner maintenance.
- Turn off all power to the appliance.
- Turn off main gas to the appliance.
- Remove top cover.
- Remove fan assembly and burner as detailed in the Burner and Cleaning section.
- Check the heat exchanger surface for soot. If soot is present, heat exchanger must be cleaned and problem corrected.
- Remove the front outer jacket door.
- Remove the front inner jacket door.
- Check "V" baffles on the exchanger.
- Use detergent water pressure wash to remove soot from heat exchanger and surfaces of the inner chamber.
- When necessary, the heat exchanger can be removed by disconnecting all water piping and removing the eight flange mounting bolts at the rear of the appliance. The heat exchanger can now be removed from the front of the appliance.
- Reinstall inner jacket door. Replace any damaged gaskets to ensure a proper air seal.
- Reinstall the burner and fan assembly.
- Reassemble all gas and water piping. Test for gas leaks.
- Reassemble outer jacket panels. Keep top cover off.
- Cycle unit and check for proper operation.
- Once proper operation is confirmed replace the top cover.

10.8 CONDENSING HEAT RECOVERY MODULE (CHRM) INSPECTION

- Inspect the CHRM annually.
- Turn off all power to the appliance.
- Turn off main gas to appliance.
- Remove the top cover, front and right side outer panels.
- Remove the CHRM access cover.
- Pressure wash the heat exchanger. Use a soft bristle brush to remove any remaining deposits.
- If necessary the heat exchanger can be removed by disconnecting all water piping and lifting it out from the

side.

10.9 RE-INSTALL HEAT EXCHANGERS

- Carefully reinstall the heat exchanger if removed from the appliance.
- Check all gaskets and replace if damaged.
- Replace heat exchanger cover.
- Reassemble outer jacket panels.
- Cycle unit and check for proper operation.
- Replace the top cover

10.10 COMBUSTION AIR FAN

Combustion air fan should be checked every 6 months. Clean internal filter to fan as required when installed in a dust or dirt contaminated location. See Combustion Air Fan in the component section for cleaning procedure. The motor and bearings on the combustion air fan are sealed and permanently lubricated requiring no addition of oil or lubricants.

10.11 COMBUSTION AND VENTILATION AIR

Check frequently to be sure that the flow of combustion and ventilation air to the appliance is not obstructed. Combustion and ventilation air must be provided to the mechanical room with openings sized per the requirements of the B149 or National Fuel Gas Code. The optional outdoor air kit brings combustion air from the outdoors directly to the appliance.

10.12 CONTROL CIRCUIT VOLTAGE

This appliance uses a transformer to supply a low voltage control circuit. The voltage on the secondary side should be 24 to 28VAC when measured with a voltmeter. A secondary voltage of 21VAC or less supplied to 24VAC components may cause operational problems. A 4A circuit breaker is provided on the secondary side of the transformer. The circuit breaker is located on the front control panel. A tripped circuit breaker indicates a short in the 24VAC controls and must be corrected.

10.13 COMBUSTIBLE MATERIALS

CAUTION

Keep appliance clear from combustible materials; do not store **GASOLINE** and other flammable vapors and liquids in the proximity of the appliance.

10.14 FREEZE PROTECTION

Installations are not recommended in areas where the danger of freezing exists. Proper freeze protection must be provided for appliances installed outdoors, in unheated mechanical rooms or where temperatures may drop to the freezing point or lower. If freeze protection is not provided for the system, a low ambient temperature alarm is recommended for the mechanical room. Damage to the appliance by freezing is non-warrantable.

- **Location** - Heating boilers, hot water supply boilers or water heaters must be located in a room having a temperature of at least 50°F (10°C)
- **Caution** - A mechanical room operating under a negative pressure may experience a downdraft in the flue of an appliance that is not firing. The cold outside air may be pulled down the flue and freeze a heat exchanger. This condition must be corrected to provide

adequate freeze protection.

- Freeze protection for the appliance using an indirect coil can be provided by using hydronic system antifreeze. Follow the manufacturer's instructions. **DO NOT** use undiluted or automotive type antifreeze.
- **Shut-down and draining** - If for any reason, the unit is to be shut off in a space where danger of freezing exists, the following precautionary measures must be taken:
 - Shut off gas supply.
 - Shut off water supply.
 - Shut off electrical supply.
 - Drain the main exchanger and the secondary exchanger, if supplied, completely.
 - Ensure that the pump and connecting piping are fully drained.

10.15 FREEZE PROTECTION FOR A HEATING BOILER SYSTEM (Optional)

- Use only properly diluted inhibited glycol antifreeze designed for hydronic systems.
- Follow the instructions from the antifreeze manufacturer. Quantity of antifreeze required is based on total system volume including expansion tank volume.
- Antifreeze is denser than water and changes the viscosity of the system. The addition of antifreeze will decrease heat transfer and increase frictional loss in the boiler and related piping. Where antifreeze has been used, to maintain the temperature rise across the appliance confirm that the recommended GPM for pure water has been increased by 15% and the head loss by 20%.
- Local codes may require a back flow preventer or actual disconnect from city water supply when antifreeze is added to the system.
- When filling or topping-up the system with water mixed with the antifreeze always use distilled or RO (reverse osmosis) water. This will prevent the reaction of the water with antifreeze which can create sludge.

PART 11 INSTALLATIONS

11.1 HEATING BOILER INSTALLATIONS

The appliance **MUST** always be installed in a primary/secondary piping system for proper operation. Before beginning the installation, consult local codes for specific plumbing requirements. The installation should provide unions and valves at the inlet and outlet of the appliance so it can be isolated for service. An air separation device must be supplied in the installation piping to eliminate trapped air in the system. Locate a system air vent at the highest point in the system. The system must also have a properly sized expansion tank installed. Typically, an air charged diaphragm-type expansion tank is used. The expansion tank must be installed close to the boiler and on the suction side of the system pump (appliance Inlet) to ensure proper operation. Caution: This appliance should not be operated at less than 15 PSIG cold. Pressure will rise when hot. Expansion tank sizing will determine the pressure when the system is hot. Do not operate the system at less than 30 PSIG when hot. Water piping must be supported by suitable hangers or floor stands, **NOT** by the appliance. Pipe systems will be subject

to considerable expansion and contraction. Pipe supports could allow the pipe to slide resulting in noise transmitted into the system. Padding is recommended. The boiler pressure relief valve must be piped to a suitable floor drain. See Section 4.2.

CAUTION

A leak in a boiler "System" will cause the "System" to intake fresh water constantly, which will cause the tubes to accumulate a line/scale build up. This will cause a **NON-WARRANTABLE FAILURE**.

11.2 WATER CONNECTIONS

All models have FIP inlet and outlet bronze connections. Pipe size must be in accordance with table 9 and, between supply and return lines, must not exceed 80 feet of equivalent length. Any reduction in recommended pipe size may decrease flow resulting in high water temperatures, boiler noise, flashing to steam and non-warrantable heat exchanger damage.

11.3 PIPING LENGTHS

The appliance circulator provides the water flow from the primary boiler piping, through the boiler and back to the primary system. Pipe diameter and length are critical to ensure proper flow through the boiler.

The secondary loop piping to and from the appliance must have a fully ported ball valve installed in both the supply and return side piping and will be used for isolation only. The ball valves must be the same diameter as the installed piping. If flow control is required, other means of flow control such as globe valve or flow setter should be used.

11.4 INTERMITTENT PUMP OPERATION

An intermittent pump operation signal is standard and can be used to operate a separate pump contactor .A ¼ hp pump delay relay is available as an option. When equipped with this option, the boiler's integral circulating pump will cycle on at each call for heat, before the burner fires. The pump will continue to operate while the burner is firing. The pump will run for a period of time until the programmed delta T between inlet and outlet is reached, after the temperature set point is satisfied. This will remove any residual heat from the combustion chamber before turning the pump off. See wiring diagram shipped with the unit.

11.5 SUMMARY

a) Typical Boiler Installations

General Plumbing Rules

- 1 Check all local codes.
- 2 For serviceability of boiler, always install unions.
- 3 Always pipe pressure relief valve to an open drain.
- 4 Locate system air vents at highest point of system.
- 5 Expansion tank must be installed near the boiler and on the suction side of the system pump.
- 6 Support all water piping.

b) Placing the Boiler in Operation

Pre-Start Check List

- 1 Review the location of the boiler, clearances from combustible surfaces and available

- service clearances.
- 2 Review Part 2 Venting. Ensure that all vent components are fabricated from the correct category of materials with adequate clearance from combustibles.
 - 3 Ensure that the boiler condensate drain and all vent system condensate drains are properly routed to an acceptable floor drain or neutralization system.
 - 4 Review the vent termination point for proper location and clearances.
 - 5 Ensure that proper volumes of combustion and ventilation air are provided to the mechanical room. If a separate combustion air pipe is used, ensure that it is properly sized, sealed and terminated.
 - 6 Review the water piping from the boiler to the system. The boiler must be installed in a primary/ secondary piping system. Review the diameter and equivalent length of the installed piping to and from the boiler to ensure proper flow.
 - 7 Ensure that a properly sized primary system pump is installed with an expansion tank.
 - 8 Check system pressure. Ensure a minimum of 30 PSIG with the system hot and not more than 90% of the rated pressure of the relief valve.
 - 9 Review the installed gas piping from the meter to the boiler. Ensure that the gas pipe, meter and any regulators are adequately sized.
 - 10 Review the field wiring and electrical service for both the boiler controls and pump. Ensure that the electrical service(s) is adequately sized.

Boiler Set-Up

- 1 Ensure that the boiler and piping system are full of water. Bleed all air from the pump housing and secondary loop.
- 2 Check system for any water leaks.
- 3 Check system for installation of glycol or water treatment where required. Where glycol has been used to maintain the temperature rise across the appliance confirm that the recommended flow for pure water has been increased by 15% and the head loss by 20%.
- 4 Turn on power to the primary system pump and the appliance secondary pump and verify operation.

Boiler Operational Checks

- 1 Turn the boiler main power switch to the "ON" position.
- 2 Verify operation of the Fuji and Diagnostic Display.
- 3 Program the adjustable points.
- 4 Turn the switch to the "ON" position to start boiler operation.
- 5 Push the resets for low water level, high water temperature and flame failure.
- 6 Install a manometer on the gas supply to the boiler and verify minimum gas supply pressure as the burner fires at 100% of rated input.
- 7 Verify operation of safeties as necessary (low water cut-off, high limit, gas pressure, etc.).

Boiler Operation

- 1 Appliance should begin the start-up process for the sequence of operation.
- 2 The boiler will fire down to 20% of rated input on initial start-up and adjust input as required to meet system demand.
- 3 Ensure that inlet water temperature does not fall below 110°F (43.3°C).
- 4 Based on system demand, the appliance will modulate accordingly.
- 5 As system demand is satisfied, the burner will cycle off and the combustion air fan will decelerate at a pre-programmed rate before the appliance shuts down.

11.6 DOMESTIC HOT WATER HEATER

Hot water heaters are designed for installation with a storage tank. The operation of the properly sized circulating pump, the piping between the tank and heater and the control of water velocity, as explained below, are important for correct operation of your hot water heater.

11.7 WATER VELOCITY CONTROL

To ensure proper velocity through the heat exchanger(s), it is necessary to select the proper pump. Temperature rise at full fire will be an indication of flow. This must be done on initial installation and periodically rechecked.

Excessive lime/scale build-up in the heat exchanger tubes is a result of restricted flow and too little velocity in the tubes. Excessive pitting or erosion in the tube is caused by high water flow and too much velocity through the tubes. Care should be taken to maintain required water velocity based on water condition as follows:

11.8 TEMPERATURE RISE AT FULL FIRING RATE

- 1 The pump must run continuously when the burner is firing.
- 2 With the pump running and the burner in the water heater or hot water supply boiler in the off cycle, the Return/Inlet temperature and Supply/Outlet temperature readings on the SmartFlame display should read approximately the same temperatures.
- 3 Turn the hot water heater on and allow time for the temperature to stabilize. Check the temperature rise when the burner is firing at 100% of rated input.
- 4 Compare the temperature rise on the SmartFlame display with the required temperature rise at the required flow rate based on water condition (Soft, Normal, and Hard). Should adjustment be needed, proceed as follows:

If the temperature rise is too high, the water velocity is too low. Adjust as follows:

- 1 Check for flow restrictions. Check for debris in strainers
- 2 Check diameter and equivalent length of the piping between the storage tank and hot water heater.
- 3 Be sure all valves are open between the hot water heater and the storage tank. Ensure that all ball valves are fully ported.
- 4 Check the pump to be sure it is running properly and that the pump motor is running in the proper direction.
- 5 Be sure the pipes between the hot water heater and storage tank are not more than a total of 80 equivalent feet between supply and return lines. If maximum

equivalent length for the specified pipe diameter is exceeded, larger diameter pipe may have to be installed to achieve correct flow and temperature rise.

- 6 Common manifold piping for multiple unit installations will require larger minimum pipe sizes and tank circulating tapping to ensure proper flow.

If the temperature rise is too low, the water velocity is too high. Adjust as follows:

- 1 Temperature rise can be increased by slowly closing the flow control valve (globe valve or flow setter) in the outlet piping from the hot water heater to the storage tank to achieve the proper temperature rise.
- 2 Sustained high water velocity and low temperature rise may result in pitting or erosion of the copper tubes in the heat exchangers. This is a non-warrantable failure. Temperature rise must be properly adjusted to achieve the specified flow rate.

The required temperature rise and the recommended pump size are based on the heating of potable water with a hardness of 7.5 to 17.0 grains per gallon and a total dissolved solids not exceeding 300 PPM. Consult the factory when heating potable water exceeding these specifications. Heating of high hardness and/or high total dissolved solids water may require a larger circulating pump, an optional Copper-Nickel heat exchanger and a revised temperature rise specification based on the water chemistry of the water to be heated. Water with a hardness of less than 5 grains per gallon will usually have a low pH which can be aggressive and corrosive causing non-warrantable damage to the heater, pump and associated piping. Corrosion due to water chemistry generally shows up first in the hot water system because heated water increases the rate of corrosive chemical reactions.

CAUTION

Temperature rise cannot be adjusted when the burner is firing at less than 100% of input rate.

11.9 WATER HEATERS

Incorrect piping of the cold water supply to the system may result in excessive low temperature operation causing condensate formation on the primary heat exchanger and operational problems. The cold water supply piping must be installed in the discharge piping from the heater to the storage tank. This allows the cold water to be tempered in the storage tank before entering the heater.

The manufacturer recommends the use of a properly sized thermostatic mixing valve to supply domestic hot water at temperatures less than 140°F (60°C). Storing the water at a higher temperature and thermostatically mixing the water will decrease the size of the storage tank and increase the available quantity of mixed hot water. Caution! Adequate care **MUST** be taken to prevent potential scald injury when storing water at 140°F (60°C) and hotter.

WARNING

Should overheating occur or the gas supply fail to shut off, do not turn off or disconnect the electrical supply to the pump, instead, shut off the gas supply at a location external to the appliance

PART 12 EXPLODED VIEW

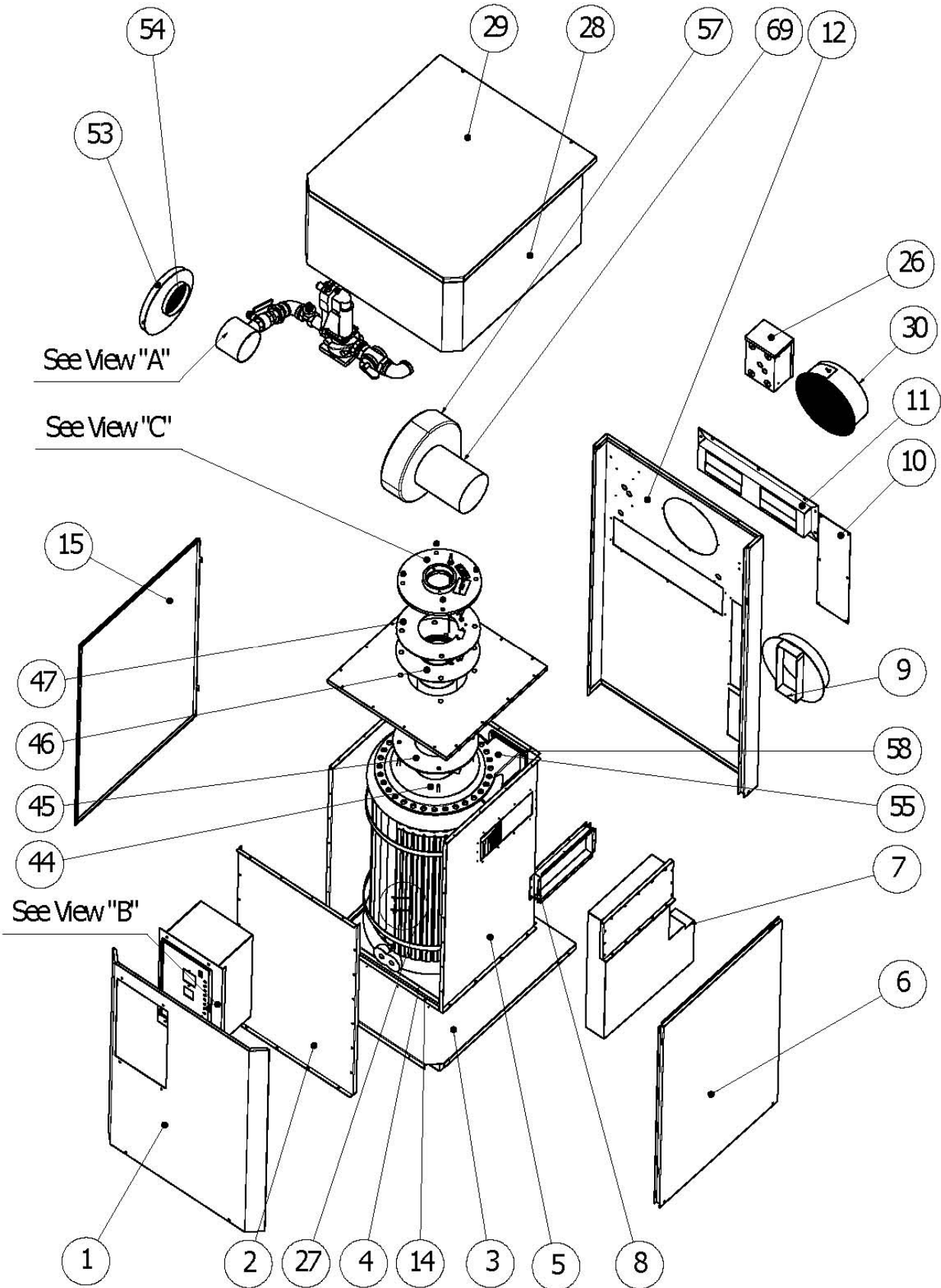

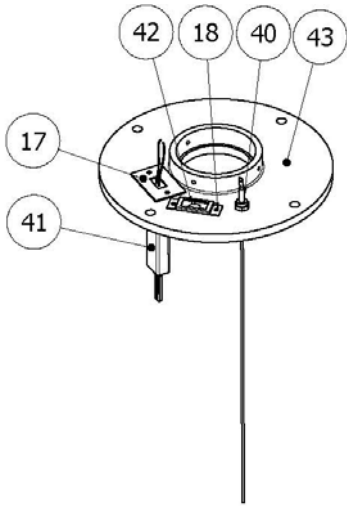

View "C"

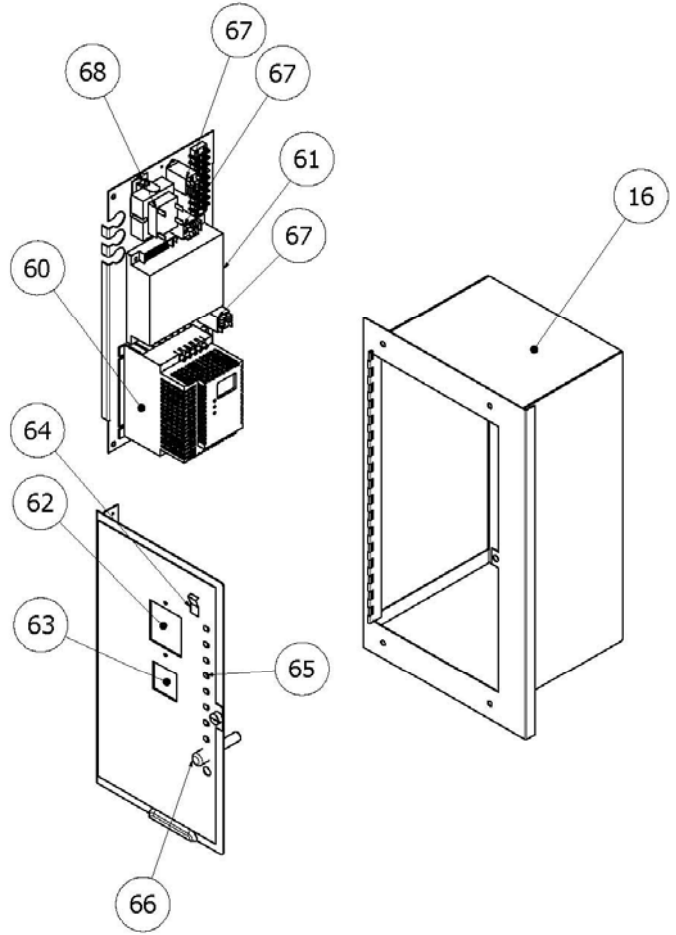
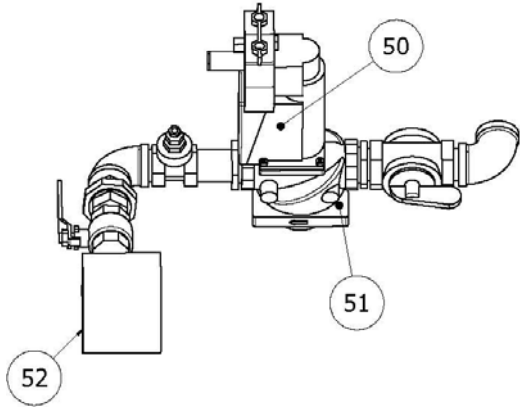

View "B"

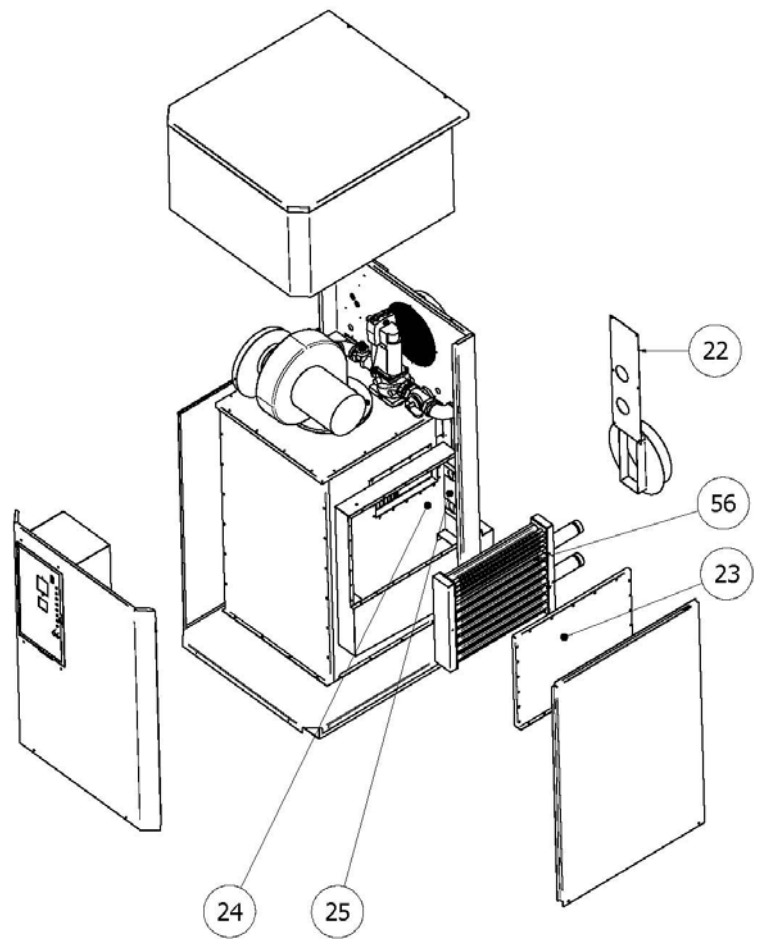
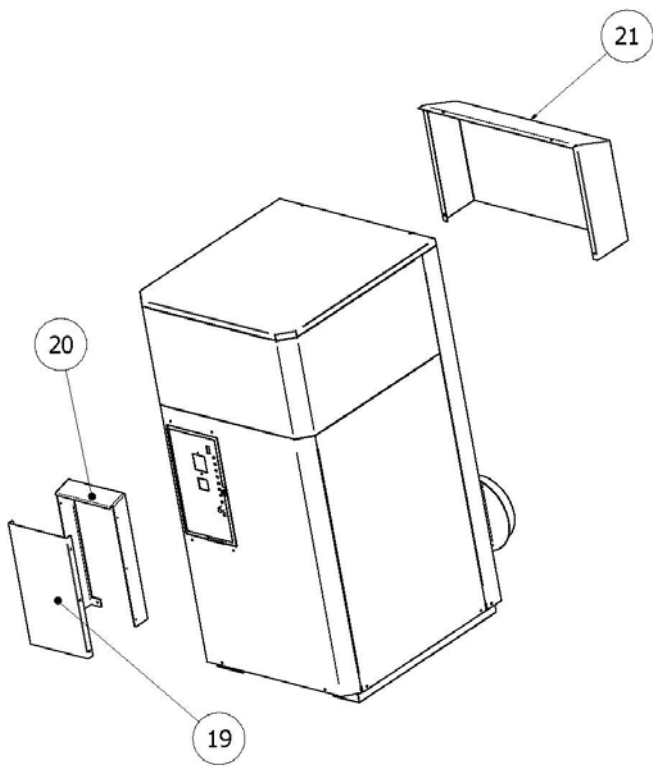

Sheet Metal Components

Ref #	Name of Part	Part ID	Model Sizes													
			ALL	500	750	1100	1200	1500	1750	2000	2500	3000	3500	4000	4500	5000
1	Outer Jacket Front Panel	14-6004		X	X	X	X									
		14-5221						X	X	X	X	X	X	X	X	X
2	Combustion Chamber Door	14-5210		X	X	X	X									
		14-5204						X	X	X	X	X	X	X	X	X
3	Base Panel	14-5012		X	X	X	X									
		14-5206						X	X	X	X	X	X	X	X	X
4	Heat Exchanger Base Support	14-5011		X	X	X	X									
		14-5205						X	X	X	X	X	X	X	X	X
5	Combustion Chamber Wrap	14-5008		X	X	X	X									
		14-5202						X	X	X	X	X	X	X	X	X
6	Outer Jacket Right Panel	14-6012		X	X	X	X									
		14-5223						X	X	X	X	X	X	X	X	X
7	Flue Outlet Transition	14-5290	X													
8	Flue Conduit	14-5014		X	X	X	X									
		14-5208						X	X	X	X	X	X	X	X	X
9	Vent Transition Disk	14-5279	X													
10	Back Cover Plate (Non-Condensing)	14-0346						X	X	X	X	X				
11	Transition Inner to Outer Jackets	14-6022		X	X	X	X									
		14-5225						X	X	X	X	X	X	X	X	X
12	Outer Jacket Rear Panel	14-5224	X													
13	Inner Top Panel	14-5009		X	X	X	X									
		14-5203						X	X	X	X	X	X	X	X	X
14	Drain Pan	14-0203		X	X	X	X									
		14-5211						X	X	X	X	X	X	X	X	X
15	Outer Jacket Left Panel	14-5222	X													
16	Electrical Enclosure	14-5260	X													
17	Ignitor Mounting Flange	14-5051	X													
18	Sight Glass Holder	14-0049	X													
19	Control Panel Outdoor Cover Door	14-5231	X													
20	Control Panel Outdoor Cover	14-5232	X													
21	Rain Canopy	14-5233	X													
22	Back Cover Plate (Condensing)	14-0347						X	X	X	X	X	X	X	X	X
23	Secondary Heat Exchanger Cover	14-5272	X													
24	Secondary Heat Exchanger Enclosure Main Section	14-5271	X													
25	Secondary Heat Exchanger Closure Plate	14-5274	X													
26	Electrical Box	14-0263	X													

27	Vee Baffle Sets	14-0350		X													
		14-0351			X												
		14-0352					X										
		14-0353						X									
		14-0354							X								
		14-0355								X							
		14-0356									X						
		14-0357										X					
		14-0358											X				
		14-0371												X	X	X	X
28	Outer Jacket Top Wrap	14-5226	X														
29	Outer Jacket Top Cover	14-5227	X														
30	Outside Air Intake Housing	GFH 6"		X													
		GFH 8"			X	X	X										
		GFH 10"						X	X								
		GFH 12"								X	X	X					
		GFH 14"											X	X	X	X	

Miscellaneous Components

Ref #	Name of Part	Part ID	Model Sizes													
			ALL	500	750	1100	1200	1500	1750	2000	2500	3000	3500	4000	4500	5000
40	Flame Rod	66-0023	X													
41	Hot Surface Ignitor	3201R	X													
42	View Port Glass	VPORTGLASS	X													
43	Burner Flange	13-5052		X	X	X	X									
		13-5330						X	X	X						
		13-5331										X				
		13-5332										X				
		13-5333											X	X	X	X
44	Inlet Outlet Header Top Gasket	33-0020		X	X	X	X									
		33-0018						X	X	X	X					
		33-0019										X				
45	Burner Support Ceramic Gasket	33-0023		X	X	X	X									
46	Main Burner	500-BRN		X												
		750-BRN			X											
		1100-BRN				X										
		1200-BRN					X									
		1500-BRN						X								
		1750-BRN							X							
		2000-BRN								X						
		2500-BRN									X					
		3000-BRN										X				
		3500-BRN											X			
		4000-BRN												X		
		4500-BRN													X	
5000-BRN														X		
47	Burner Flange Support Gasket	33-0015		X	X	X	X									
		33-0017						X	X	X	X					
		33-0021										X	X	X	X	X
50	Valve Actuator	SKP50.191U17	X													

51	Valve Body	VGG10.2544	X															
52	Air Gas Inlet Adapter	66-5000		X	X	X												
		66-5001					X											
		66-5003							X	X	X							
		66-5004										X	X					
		66-5005												X	X	X	X	
53	Filter Holder	GFH-500-CH		X														
		GFH-750-CH			X													
		GFH-1100-CH				X												
		GFH-1200-CH					X											
		GFH-1500-CH						X										
		GFH-1750-CH								X								
		GFH-2000-CH									X							
		GFH-2500-CH										X						
		GFH-3000-CH											X					
		GFH-3500-CH												X				
		GFH-4000-CH													X			
		GFH-4500-CH														X		
GFH-5000-CH															X			
54	Fan Intake Filter	GFIF-500-CH		X														
		GFIF-750-CH			X													
		GFIF-1100-CH				X												
		GFIF-1200-CH					X											
		GFIF-1500-CH						X										
		GFIF-1750-CH								X								
		GFIF-2000-CH	-								X							
		GFIF-2500-CH	-									X						
		GFIF-3000-CH											X					
		GFIF-3500-CH												X				
		GFIF-4000-CH													X			
		GFIF-4500-CH														X		
GFIF-5000-CH															X			
55	Primary Heat Exchanger (Vee Baffles Excluded)	500-HTX		X														
		750-HTX			X													
		1100-HTX				X												
		1200-HTX					X											
		1500-HTX						X										
		1750-HTX								X								
		2000-HTX									X							
		2500-HTX										X						
		3000-HTX											X					
		3500-HTX												X				
		4000-HTX													X			
		4500-HTX														X		
5000-HTX															X			
56	Secondary Heat Exchanger	CAM 500		X														
		CAM 1750			X	X	X	X	X									
		CAM 3000								X	X	X						
		CAM 5000											X	X	X	X		
57	Fan Intake Filter	AF9		X	X	X	X	X	X	X								
		AF10									X	X						
		AF12											X	X	X	X		

58	Flange Gasket	33-0013		X	X	X	X									
		33-0014						X	X	X	X	X	X	X	X	X

Electrical Components

Ref #	Name of Part	Part ID	Model Sizes													
			ALL	500	750	1100	1200	1500	1750	2000	2500	3000	3500	4000	4500	5000
60	Variable Frequency Drive (1/2HP, 1HP, 1 1/2HP, 3HP)	SM005S		X	X	X	X									
		SM010S						X	X	X						
		SM015S									X	X				
		SM23S											X	X	X	X
61	Ignition Module	DF 35-67	X													
62	Control	BTC-2PA	X													
63	Control	PXZ	X													
64	On/Off Switch	W51A152A	X													
65	Indicator Lights	IND.LGT.SET	X													
66	Fuse	BK/AGC-4	X													
67	24V/120V Relays	LY1F 24/120	X													
68	75VA Transformer	HCT-01J28807	X													
69	Electrical Motor	1/2 HP		X	X	X	X									
		1 HP						X	X	X						
		1 1/2 HP									X	X				
		3 HP											X	X	X	X

PART 13 ELECTRICAL DIAGRAMS

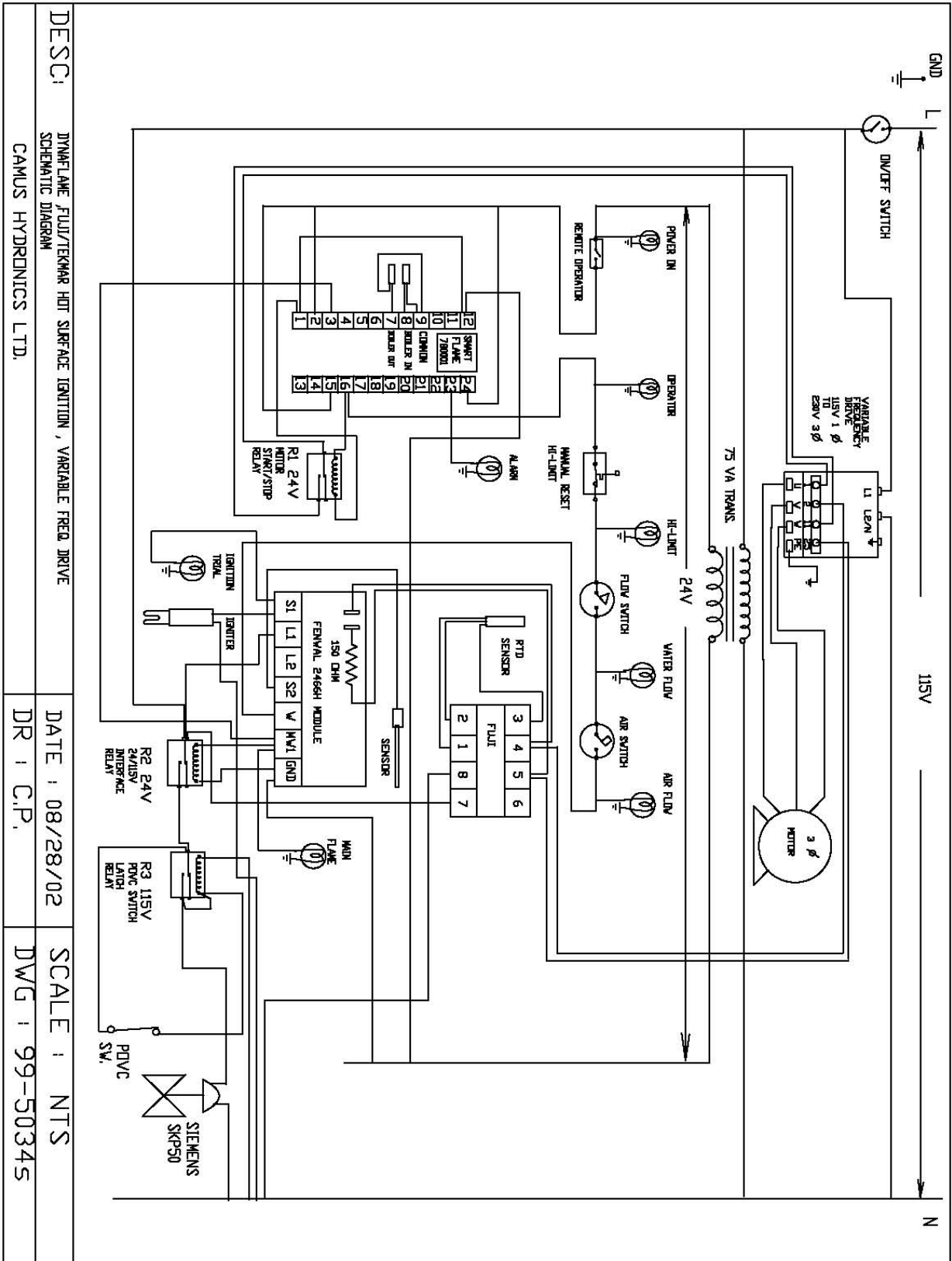

DESC: DYNAMIC FLAME FLUID/TEKNAR HOT SURFACE IGNITION, VARIABLE FREQ DRIVE

SCHEMATIC DIAGRAM

CAMUS HYDRONICS LTD.

DATE: 08/28/02

DR: C.P.

SCALE: NTS

DWG: 99-50345

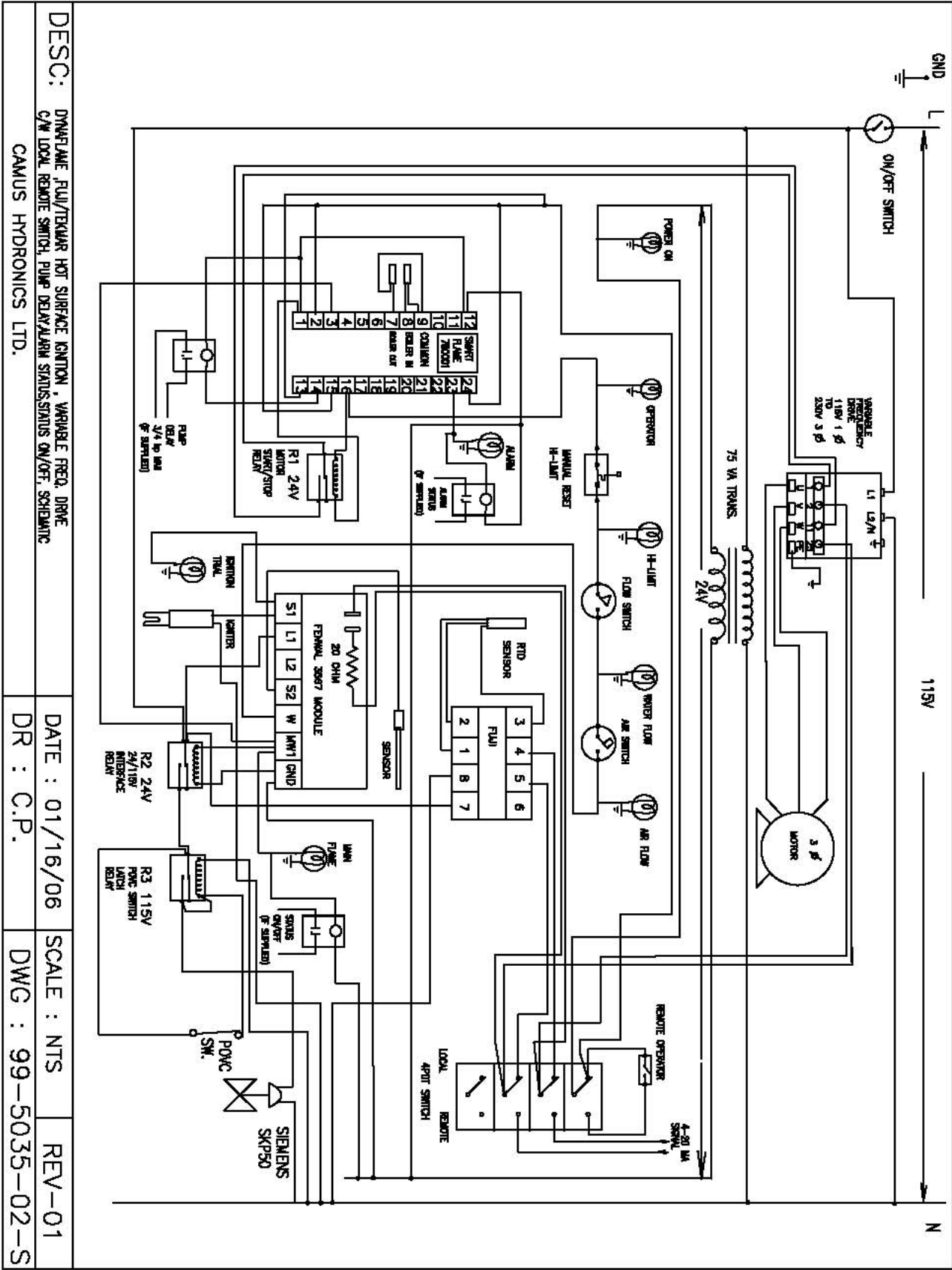

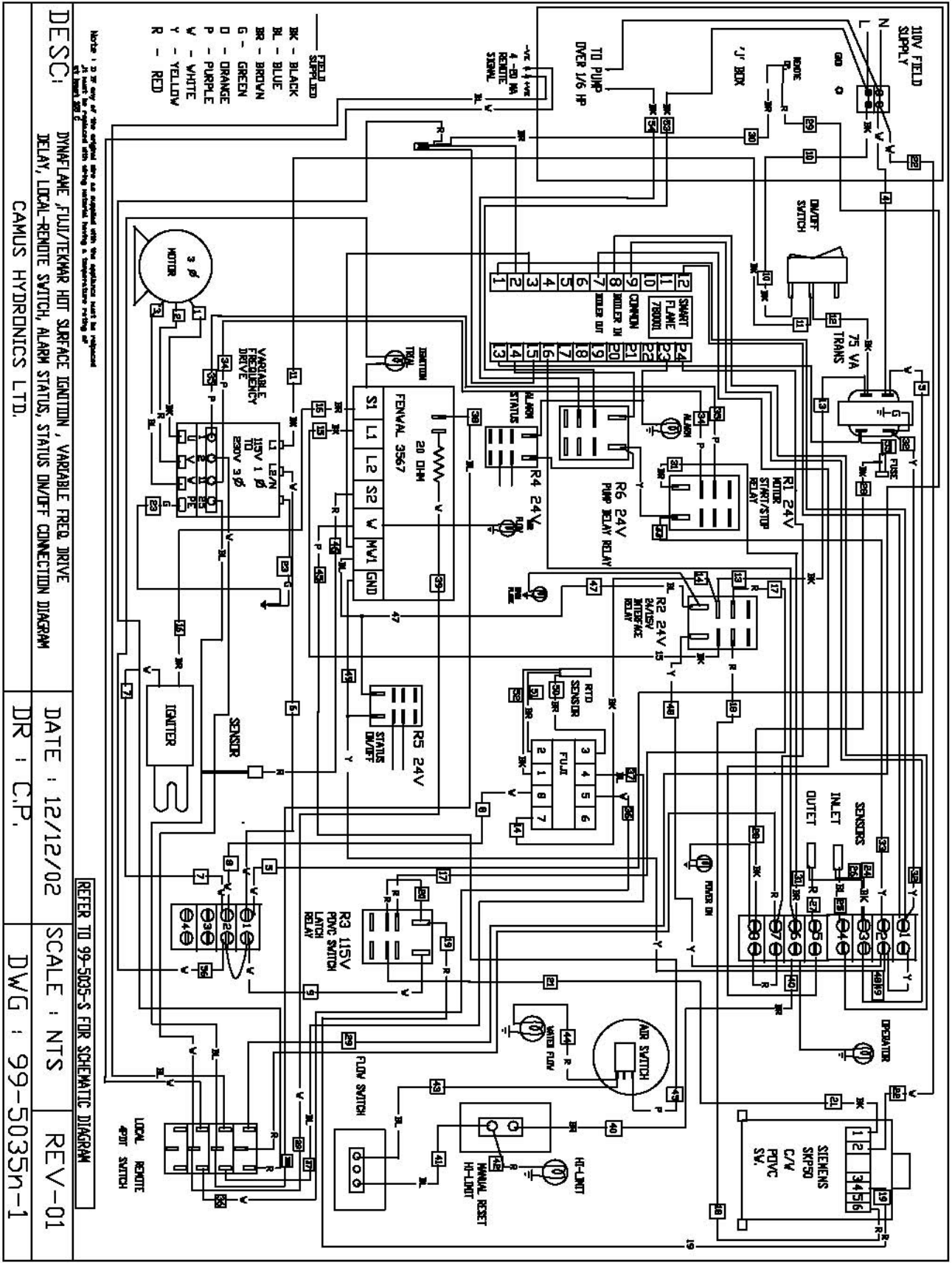

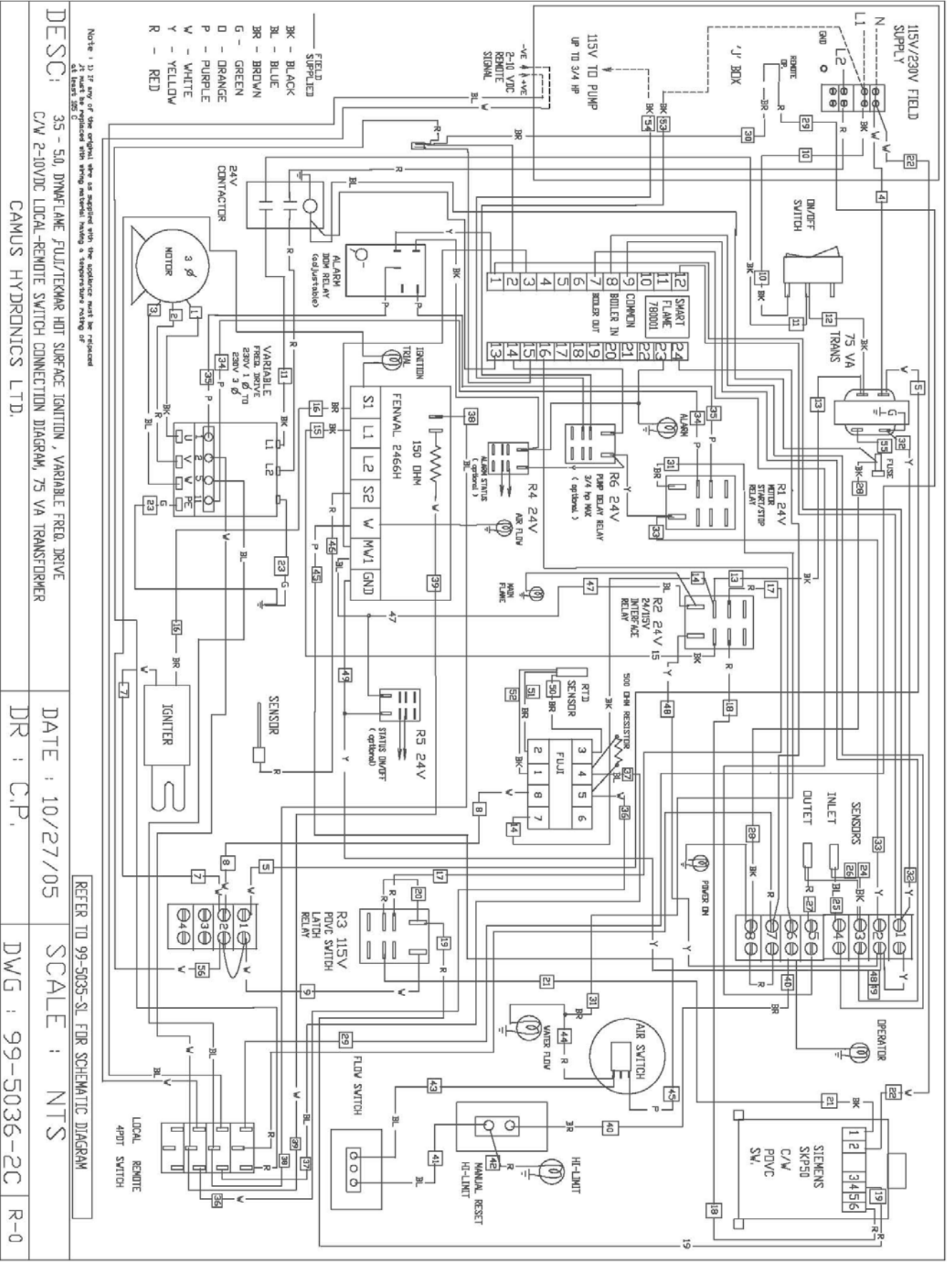

Note: 1) If any of the original wire is modified with the assistance must be indicated at least 300 C

DESCI:

35 - 50, DYNAMALNE FULU/TEKMAR HIT SURFACE IGNITION, VARIABLE FREQ. DRIVE C/W 2-10VDC LOCAL-REMOTE SWITCH CONNECTION DIAGRAM, 75 VA TRANSFORMER

CAMUS HYDRONICS LTD.

DATE : 10/27/05

DR : C.P.

SCALE : NTS

DWG : 99-5036-2C R-0

REFER TO 99-5035-SL FUR SCHEMATIC DIAGRAM

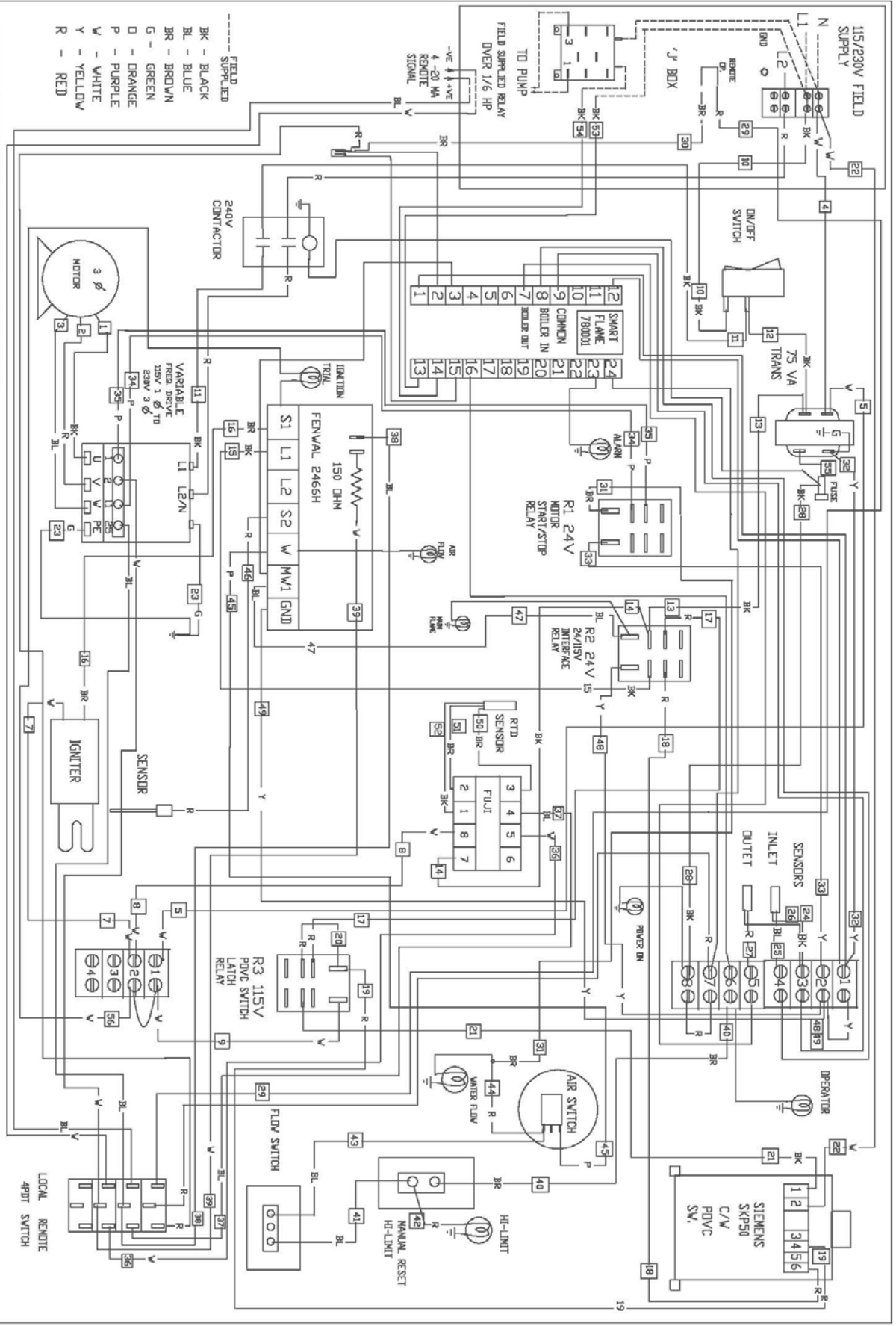

DESCI: 35 - 50 DYNAFLEAME FLUID/TEKMAR HOT SURFACE IGNITION, VARIABLE FREQ. DRIVE
 C/W LOCAL-REMOTE SWITCH CONNECTION DIAGRAM, 75 VA TRANSFORMER

DATE: 05/25/04
 SCALE: NTS
 DWG: 99-5036nL R-01

REFER TO 99-5035-SL FOR SCHEMATIC DIAGRAM

CAMUS HYDRONICS LTD.

WARRANTY

GENERAL

Camus Hydronics Limited ("Camus"), extends the following LIMITED WARRANTY to the owner of this appliance, provided that the product has been installed and operated in accordance with the Installation Manual provided with the equipment. Camus will furnish a replacement for, or at Camus option repair, any part that within the period specified below, shall fail in normal use and service at its original installation location due to any defect in workmanship, material or design. The repaired or replacement part will be warranted for only the unexpired portion of the original warranty. This warranty does not cover failures or malfunctions resulting from: (1) Failure to properly install, operate or maintain the equipment in accordance with Camus' manual; (2) Abuse, alteration, accident, fire, flood, foundation problems and the like; (3) Sediment or lime build-up, freezing, or other conditions causing inadequate water circulation; (4) Pitting and erosion caused by high water velocity; (5) Failure of connected systems devices, such as pump or controller; (6) Use of non-factory authorized accessories or other components in conjunction with the system; (7) failing to eliminate air from, or replenish water in, the connected water system; (8) Chemical contamination of combustion air or use of chemical additives to water.

HEAT EXCHANGER

If within TEN years after initial installation of the appliance, a heat exchanger, shall prove upon examination by Camus to be defective in material or workmanship, Camus will exchange or repair such part or portion on the following pro rated limited warranty. (1) Years one through five - standard warranty (2) Years six through ten - replacement purchase price pro rated at the following schedule: Year six - 60%, Year seven - 65%, Year eight -70%, Year nine -75% Year ten -80% of the current list price of the current list price This term is reduced to FIVE years if the appliance is used for other than hydronic space heating. Heat Exchanger shall be warranted for (20) years from date of installation against "Thermal Shock" (excluded, however, if caused by appliance operation at large changes exceeding 150 °F between the water temperature at intake and appliance temperature, or operating at appliance temperatures exceeding 230 °F). The Condensing Heat Recovery Module is warranted for a period of FIVE years.

BURNER

If within FIVE years after initial installation of the appliance a burner shall prove upon examination by Camus to be defective in material or workmanship, Camus will exchange or repair such part or portion.

ANY OTHER PART

If any other part fails within one (1) year after installation, or eighteen (18) months from date of factory shipment based on Camus' records, whichever comes first. Camus will furnish a replacement or repair that part. Replacement parts will be shipped f.o.b. our factory.

HOW TO MAKE A CLAIM

Any claim under this warranty shall be made directly to Camus Hydronics Limited Canadian Head Office

SERVICE LABOR RESPONSIBILITY

Camus shall not be responsible for any labour expenses to service, repair or replace the components supplied. Such costs are the responsibility of the owner.

DISCLAIMERS

Camus shall not be responsible for any water damage. Provisions should be made that in the event of a water/appliance or fitting leak, the resulting flow of water will not cause damage to its surroundings.



Name of Owner	_____	Name of Dealer	_____
Address	_____ _____	Address	_____ _____
Model No.	_____	Serial No.	_____
Date of Installation:	_____	Date of Initial Operation:	_____

6226 Netherhart Road, Mississauga, Ontario, L5T 1B7, CANADA

CAMUS Hydronics is a manufacturer of replacement parts for most copper finned

water heaters and heating boilers as well as a

supplier of specialty HVAC products. Our service line is open 24 hours, 7 days a week!

The CAMUS CERTIFIED! Seal assures you that Reliability, Efficiency & serviceability are built

into every single unit! For more information



on our innovative products from CAMUS Hydronics Limited, call 905-696-7800 today.



CAMUS HYDRONICS LTD.

6226 Netherhart Road, Mississauga, Ontario L5T 1B7

TEL: 905-696-7800 FAX: 905-696-8801